

A. HODUNOV, G. GORBENKO, P. GAKAL*National Aerospace University «Kharkiv Aviation Institute», Ukraine***THE CALCULATION OF THE HEAT CONTROL ACCUMULATOR VOLUME OF TWO-PHASE HEAT TRANSFER LOOP OF A SPACECRAFT THERMAL CONTROL SYSTEM**

Spacecraft thermal control systems based on two-phase mechanically pumped loops have advantages in terms of mass and power consumption for auxiliary needs compared to single-phase thermal control systems. However, the disadvantage of two-phase mechanically pumped loops is that when changing the heat load and heat removal conditions, when switching from single-phase to two-phase operation mode and vice versa, the amount of working fluid in the loop changes significantly, which requires the use of a large volume heat-controlled accumulator. Therefore, determining the minimum required volume of the heat-controlled accumulator for the loop operation is an urgent task due to the need to maintain the performance of the loop at a minimum and maximum heat loads and minimize the mass of the structure and the working fluid charged. When determining the volume of the heat-controlled accumulator, it is necessary to correctly calculate the mass of the fluid in the loop during the two-phase operation mode. The mass of the fluid depends on the void fraction, which depends significantly on the phase slip. Many models and correlations have been proposed to calculate the phase slip factor. However, they all require justification for the parameters characteristic of spacecraft thermal control systems and weightlessness conditions. The paper presents the results of ground-based experiments, based on which the verification of different models and correlations for phase slip was performed. The validation of models and correlations for the conditions of weightlessness was performed by comparing the results with the horizontal and vertical orientation of the elements of the experimental setup. The working fluid is ammonia. The experiments showed that the best coincidence of calculation and experience is provided by Chisholm correlation. The discrepancy between the calculated and experimental values did not exceed +/-7% in the entire range of study parameters both for horizontal and vertical orientations, which allow us to recommend the Chisholm correlation for determining the coolant mass in the two-phase mechanically pumped loops for parameters characteristic of spacecraft thermal control systems, including zero-gravity conditions.

Keywords: spacecraft; weightlessness; thermal control system; two-phase mechanically pumped loop; heat-controlled accumulator; volume; ammonia; slip factor.

Introduction

For spacecraft (SC) with large heat dissipation (more than 6 kW), the most promising is thermal control systems (TCS) are based on a two-phase mechanically pumped loop (2PMPL) [1]. The NASA Technology Roadmap [2] classifies mechanically pumped two-phase loops as preferred for a series of future agency space missions. 2PMPL has many advantages compared to single-phase TCS, which, as a consequence, lead to significant weight savings of the system [3, 4]. A simplified schematic diagram of TPL with pumped fluid is shown in Fig. 1.

The loop consists of a pump (P), heat acquisition system (HAS), including thermal sinks/evaporators (EV), heat rejection system (HRS) with condensers (C), heat-controlled accumulator (HCA), liquid (Liquid), and vapor (Vapor) lines. The liquid work fluid is pumped by

the pump (P) to the heat acquisition system (HAS), where it flows through the thermal sinks/evaporators (EV), where it is supplied with heat. As a result, the working fluid is heated to saturation, evaporates, and enters the two-phase state. The two-phase fluid enters the condensers (C) of the heat rejection system (HRS) where it is condensed and supercooled, as a result of heat removal to the environment, and then enters the pump through the liquid line (Liquid). The Heat Controlled Accumulator (HCA) is required to regulate the parameters of the loop as well as to compensate for changing the amount of fluid in the loop when the operating conditions of the loop change.

The most promising is the heat-controlled accumulator (HCA) [5 – 7].

As follows from the working principle, 2PMPL has a disadvantage compared with a single-phase loop: when changing the heat load and heat removal condi-

tions, when switching from single-phase to two-phase mode and vice versa, the amount of working fluid in the loop changes significantly, especially in the case of a large volume of the two-phase section compared with the volume of the entire loop. Therefore, it is necessary to have a sufficiently accurate method of calculating the required volume of HCA, because if the volume of HCA is underestimated, the loop can lose control or fail at close to the limit operating modes, and overestimated volume of HCA will increase the weight of the system and the charged working fluid.

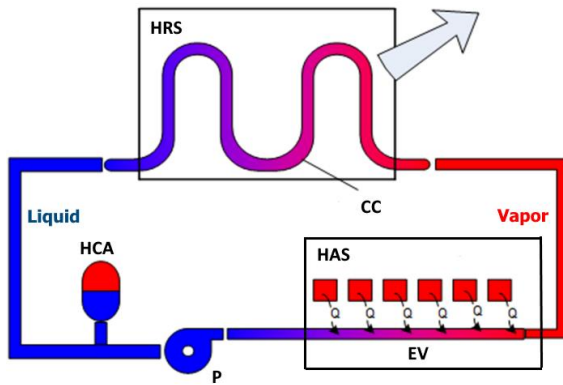

Fig. 1. Conceptual diagram of the 2PMPFL:
P – pump; HAS – heat acquisition system; EV – thermal sinks / evaporators; HRS- heat rejection system;
C – condensers; HCA – heat-controlled accumulator;
Liquid – liquid line; Vapor – vapor line

1. Required HCA volume calculation

The required HCA volume V_{HCA} is equal to the volume of liquid working fluid that the accumulator must absorb or deliver to the loop, plus the guaranteed vapor pad volume in “cold” mode and the residual liquid volume in “hot” mode of operation of the loop. In this case, it is still possible to regulate the loop parameters using HCA, including the limit “cold” and “hot” modes. The mass of the fluid flowing in/out of the HCA is determined as the difference of the working fluid mass in the loop in single-phase mode M_{loop}^{cold} (minimum heat loads, “cold” orbit) and in two-phase mode M_{loop}^{hot} (maximum heat loads, “hot” orbit).

The main calculation formula for the volume of HCA can be described as:

$$V_{HCA} = (M_{loop}^{cold} - M_{loop}^{hot}) / (\rho_m^{hot} - \rho_m^{cold}), \quad (1)$$

where: ρ_m^{hot} the average density of the two-phase mixtures in the HCA in the “hot” mode, kg/m^3 ; ρ_m^{cold} the average density of the two-phase mixture in the HCA in the “cold” mode, kg/m^3 .

Average density of the two-phase mixture in the HCA in the “hot” mode:

$$\rho_m^{hot} = \varphi_{hot} \cdot \rho_V(t_{max}) + (1 - \varphi_{hot}) \cdot \rho_L(t_{max}), \quad (2)$$

where φ_{hot} – ratio of vapor volume to full HCA volume in “hot” mode;

$\rho_V(t_{max})$ – vapor density at temperature t_{max} kg/m^3 ;

$\rho_L(t_{max})$ – liquid density at temperature t_{max} kg/m^3 ;

t_{max} – temperature of the working fluid in the HCA at the maximum heat dissipation in the loop and “hot” orbit.

Average density of two-phase mixture in HCA in “cold” mode:

$$\rho_m^{cold} = \varphi_{cold} \cdot \rho_V(t_{min}) + (1 - \varphi_{cold}) \cdot \rho_L(t_{min}), \quad (3)$$

where φ_{cold} – ratio of vapor volume to full HCA volume in “cold” mode;

$\rho_V(t_{min})$ – vapor density at temperature t_{min} kg/m^3 ;

$\rho_L(t_{min})$ – liquid density at temperature t_{min} kg/m^3 ;

t_{min} – temperature of the working fluid in the HCA at the maximum heat dissipation in the loop and “cold” orbit.

Formula (1) considers safety factors by setting $\varphi_{hot} > 0$ and $\varphi_{cold} < 1$ then calculating the average density of working fluid in the HCA.

The accuracy of the calculation of the required volume of HCA affects the performance of the circuit at the limit “cold” and “hot” modes and the possibility of regulating its parameters using HCA.

The main ways to reduce the required volume of HCA, based on the structure of formula (1), are as follows: it is necessary to increase M_{loop}^{hot} and ρ_m^{hot} decrease M_{loop}^{cold} and ρ_m^{cold} . Analysis shows that the possibility of influencing the value M_{loop}^{cold} and M_{loop}^{hot} by changing the parameters of the working fluid (e.g., flow rate) for the loop of a given design at a given value of the maximum heat load and heat dissipation conditions, are limited. Therefore, the main way to reduce the HCA volume is to increase ρ_m^{hot} and the “hot” mode and decrease ρ_m^{cold} and the “cold” mode. In the limit it means: to allow 100 % filling of HCA with liquid in the “hot” mode ($\varphi_{hot} = 0$ and complete emptying of HCA in the “cold” mode ($\varphi_{cold} = 1$. But for this purpose, it is necessary to be able to calculate very accurately the necessary volume of heat-controlled accumulator.

At the stage of 2PMPL design, there are uncertainties and errors in calculating the mass of the fluid in the

loop. Especially great is the error in calculating the mass M_{loop}^{hot} the two-phase mode at the maximum heat load and the worst heat removal conditions. This forces the entry of increased reserve coefficients by setting $\varphi_{hot} > 0$ and $\varphi_{cold} < 1$ which negatively affects the volume and total mass of the heat-controlled accumulator and TCS.

2. Working fluid mass calculation in the loop for two-phase mode

The mass of the working fluid in the loop is equal to the sum of the masses in the individual sections. To calculate the total mass of the working fluid, the entire 2PMPL must be divided into elementary sections, within which the flow parameters can be assumed to be unchanged.

Calculation of the working fluid mass in sections with single-phase liquid working fluid (liquid lines, pump, etc.) is not difficult, it is enough to know the temperature of the working fluid in these elements and the geometric parameters of the loop [8, 9].

Calculation of working fluid mass in sections with two-phase working fluid (evaporators, vapor lines, and condensers) presents significant difficulties since the mass is determined not only by the geometry and temperature of the working fluid but also by the distribution of mass and volume vapor quality, the slip of phases along the length of the channel.

The mass of the two-phase working fluid in an elementary section of a cylindrical pipeline of length ΔX can be estimated by the formula:

$$\Delta M_{2p} = \Delta V_{2p} \cdot \rho_m, \quad (4)$$

where $\Delta V_{2p} = F \cdot \Delta X$ - volume of the elementary section of the loop with two-phase working fluid, m^3 ;

F - cross-sectional area of the channel, m^2 ;

ΔX - length of elementary section, m ;

ρ_m - average density of two-phase working fluid in this section, kg/m^3 .

The average density of the two-phase working fluid depends on the phase densities and the void fraction.

$$\rho_m = \rho_L - \alpha \cdot (\rho_L - \rho_V), \quad (5)$$

where $\alpha = 1 / (1 + \frac{1-x}{x} \cdot \frac{\rho_V}{\rho_L} \cdot S)$ the void fraction.

In the equations:

ρ_L and ρ_V - density of liquid and vapor phases, kg/m^3 ,

x - vapor quality;

$S = \frac{u_V}{u_L}$ - slip factor;

u_V and u_L - average velocity of liquid and vapor phases, m/s .

Thus, in order to correctly estimate the mass of the working fluid in the loop, along with other parameters, if is necessary to know the void fraction, which, in turn, depends significantly on the slip factor S .

Various models have been proposed to estimate the slip factor.

- Homogeneous flow for which the slip factor [10]:

$$S=1.0;$$

- Momentum Flux Model [11]:

$$S = \left(\frac{\rho_L}{\rho_V} \right)^{1/2}; \quad (6)$$

- Zivi Kinetic Energy Model for annular flow [12]:

$$S = \left(\frac{\rho_L}{\rho_V} \right)^{1/3}; \quad (7)$$

- Levy Momentum Model [13]. The void fraction is defined by the equation solving:

$$x = \frac{\alpha(1-2\alpha)\alpha\sqrt{(1-2\alpha)^2 + \alpha(2\frac{\rho_L}{\rho_V}(1-2\alpha)^2 + \alpha(1-2\alpha))}}{2\frac{\rho_L}{\rho_V}(1-2\alpha)^2 + \alpha(1-2\alpha)}; \quad (8)$$

- Chisholm Method [14]:

$$S = (1-x(1-\frac{\rho_L}{\rho_V}))^{1/2}; \quad (9)$$

- Model proposed by M. Narcy et al. [15], in accordance with this model:

$$\alpha = \frac{f \cdot x^n}{1 + (f-1)x^n}, \quad (10)$$

where coefficients $f = a + (1-a)(\frac{\rho_V}{\rho_L})^{a_1}$ and

$n = b + (1-b)(\frac{\rho_V}{\rho_L})^{a_1}$ with values: $a = -2.129$,

$b = 0.3487$, $a_1 = -0.2186$, $b_1 = 0.515$.

As the authors point out, this model describes well the void fraction in microgravity conditions.

As an example, let's calculate the mass of ammonia in a section of adiabatic pipeline with a diameter of 7 mm and a length of 13.7 m. The flow parameters are as follows: vapor quality - 0.5; saturation temperature - 65°C. Calculation result: if there is no slip ($S=1$) $\Delta M_{2p} = 0.047$ kg; calculating the slip factor by Chisholm's model $\Delta M_{2p} = 0.097$ kg.

The conclusion is clear: the slip of the phases must be included when calculating the mass of the working

fluid in the loop in the two-phase modes of its operation.

3. Model verification for calculating the slip factor

The slip factor S depends on many mode parameters and channel geometry. The applicability of slip modeling proposed by various authors to calculate slip under specific conditions requires, as a rule, experimental verification.

Therefore, a set of experiments was performed to determine an acceptable model for calculating the slip of phases in an experimental two-phase heat transfer loop at different orientations of the evaporator branch. At the same time, the same slip model was used to calculate the working fluid mass in all two-phase sections of the loop.

The mass difference in the two-loop operating modes (single-phase and two-phase) was also calculated theoretically. The discrepancy between the calculated and experimental determination is the main criterion for the applicability of one or another calculation model for determining the mass of the working fluid in 2PMPL.

3.1. Experimental setup description

Fig. 2 shows a diagram of the experimental loop, on which the study was conducted. The working fluid is ammonia.

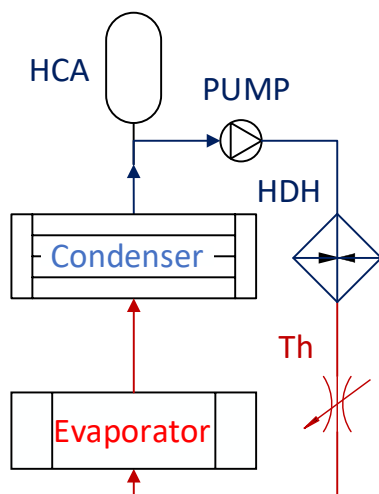

Fig. 2. Conceptual diagram of the experimental loop

The experimental setup was a single-loop loop containing pump (Pump), heater (HDH), single-phase transport sections, evaporator (Evaporator), two-phase transport section, condenser (Condenser). The pressure in the loop is regulated by a heat-controlled accumulator (HCA). All elements are located in the same horizontal

plane. The evaporator branch could take horizontal or vertical position.

The evaporator is a heat exchanger with 10 heat sinks connected in series with a channel diameter of 7 mm, on which 10 heaters with a total capacity of 6 kW are installed. The total length of the evaporator is 13700 mm.

The two-phase pipeline connects the evaporator and condenser and is designed as a tube with a diameter of 7 mm and a length of 7000 mm.

The condenser is a connected two-channel aluminum profile. One channel is filled with two-phase ammonia and the other with coolant glycol. The condensation section is significantly shorter than the other two-phase sections.

The HCA was mounted on a high-precision weight scale.

3.2. Experimental procedure

At first, a series of experiments were performed in the two-phase mode. The loop was set to stationary mode with the following specified parameters:

- Saturation temperature in HCA T_{HCA} ;
- mass flow rate of working fluid m ;
- subcooling at the evaporator branch inlet ΔT_{sub} ;
- glycol temperature T_{glic} ;
- total supplied power Q_{el} .

The main part of the experiments was performed with all evaporator heaters turned on simultaneously.

After reaching the steady-state mode, all parameters of the 2PMPL were recorded, including the HCA mass in the two-phase mode M_{HCA_2f} and the total injected electric power Q_{el} .

After conducting a series of experiments in two-phase mode, all evaporator heaters (except the heater (HDH)) were switched off, the 2PMPL was switched to single-phase mode, while the flow rate and temperatures along the length of the single-phase part of the loop were maintained. All parameters of the 2PMPL were fixed, including the mass of the HCA in single-phase mode M_{HCA_1f} . Thus, the mass of fluid in "single-phase" elements of 2PMPL (pump, transport liquid pipeline) in "two-phase" and "single-phase" modes of 2PMPL operation remained unchanged.

Mass difference:

$$\Delta M_{HCA} = M_{HCA_2f} - M_{HCA_1f} \quad (11)$$

determines the change of fluid mass in the loop only in "two-phase" elements of 2PMPL ΔM_{MPL} : in evaporator branch, transport two-phase pipeline and condenser:

$$\Delta M_{HCA} = M_{MPL} \quad (12)$$

In other "single-phase" 2PMPL elements, the change in mass is negligible, since the temperature of the liquid fluid remained approximately constant.

The error in determining the heat supplied to the evaporators was determined in special calibration experiments and was as follows:

- at $T_{\text{sat}} = 55 \text{ }^\circ\text{C}$ – no more than 30W;
- at $T_{\text{sat}} = 75 \text{ }^\circ\text{C}$ – no more than 40W.

The main error in calculating the vapor quality of x_{ex} behind the evaporator is the amount of heat supplied to the fluid. Since the flow rate and electrical power were measured with high accuracy, the error is mainly determined by the error in calculating heat losses.

– for flow rates greater than 2 g/s, the relative error in determining the vapor quality was: 4...5 % for $x \approx 0,4$; 2...3 % for $x \approx 0,8$.

– for flow rates less than 2 g/s the relative error of vapor quality determination was 5...14 %.

The mass difference of the fluid in the HCA ΔM_{HCA} is determined in experiments with high accuracy. The division value of the used scales is 1 g. The relative error of determining the fluid mass in the two-phase part of the loop did not exceed 1.8 %.

3.3. Working fluid mass calculation in two-phase part of the loop

To calculate the mass of working fluid in the two-phase part of the loop, a mathematical model of stationary flow distribution in the heat transfer loop was used. The ammonia mass in the two-phase section of the loop depends on the temperature, vapor quality distribution along the length of the channel, and slip between the phases. The heat input configuration in the evaporator was taken into account. The models for determining the slip factor of the phases were set the same in all two-phase elements of the loop.

3.4. Experimental results and comparison with calculations

Six series of experiments on ammonia were performed. The range of parameter changes in the experiments was as follow:

- saturation temperature in HCA $T_{\text{HCA}} = 55^\circ\text{C}$ and $75 \text{ }^\circ\text{C}$;
- mass flow rate $m = 0,8 \dots 16 \text{ gm/s}$;
- vapor quality at evaporator branch outlet $x_{\text{ex}} = 0,12 \dots 0,8$;
- subcooling at the evaporator inlet $\Delta T_{\text{sub}} \sim 5 \dots 25 \text{ K}$;
- glycol temperature $T_{\text{glic}} \sim 20 \dots 50 \text{ }^\circ\text{C}$.

During changes in the heat load, the main change in the mass of the working fluid occurs in the elements with two-phase loop: in the evaporator, the transport section and in the condenser. Therefore, in the following we consider only the two-phase sections of the loop.

The volumes of the “two-phase” elements of the experimental 2PMPL were as follows:

- total volume of two-phase part of 2PMPL is 1,207 L (100%);
- evaporator volume is 0,556 L (46,1%);
- volume of two-phase transport section is 0,57 L (47,2%);
- volume of the condensation section $\sim 0,081 \text{ L}$ (6,7%).

Comparison of calculated and experimental values of coolant mass changes in the two-phase section of the loop during “single-phase” and “two-phase” modes served as a criterion for the applicability of this or that correlation to solve the problem of calculating the ammonia mass in the 2PMPL. In Fig. 3 a comparison was made when using the Chisholm model in the mathematical model of 2PMPL and different orientations of the evaporator.

A comparison of calculated and experimental values using other models shows that the Chisholm model provides the best match. The mismatch between the calculated and experimental values of the change in mass does not exceed +/-7% in the entire range of parameters of the experiments conducted for both horizontal and vertical orientations. The Chisholm model can also be recommended for calculating the working fluid mass in 2PMPL under weightlessness conditions since it has shown the best agreement between the calculated and experimental results in ground experiments in a wide range of parameters characteristic of TCS and for various evaporator orientations.

To select the best phase slip model, the parameter was also used:

$$\text{RMS} = \sqrt{\frac{1}{N} \sum_{i=1}^N \left(\frac{\Delta M_{\text{exp},i} - \Delta M_{\text{sim},i}}{\Delta M_{\text{exp},i}} \right)^2}, \quad (13)$$

where N – the number of experimental points;

ΔM_{exp} – mass change of the working fluid in the HCA in the experiment;

ΔM_{sim} – estimated mass change of the working fluid in the loop.

The RMS value for different series of experiments, saturation temperatures, evaporator orientation, and the model used to calculate the slip is shown in Table 1.

A comparison of the calculated and experimental values of the change in masses according to the RMS parameter shows that:

– Chisholm model provides the best match between the calculated and experimental values of the mass change for the horizontal orientation;

– for the vertical orientation, the best match is given by the Zivi and Levy models. However, for the verti-

cal orientation the RMS discrepancy for the Zivi, Levy, and Chisholm models is insignificant. Therefore, it is recommended to use the Chisholm model for both horizontal and vertical orientations of the evaporator for convenient processing of the results of ground-based experiments.

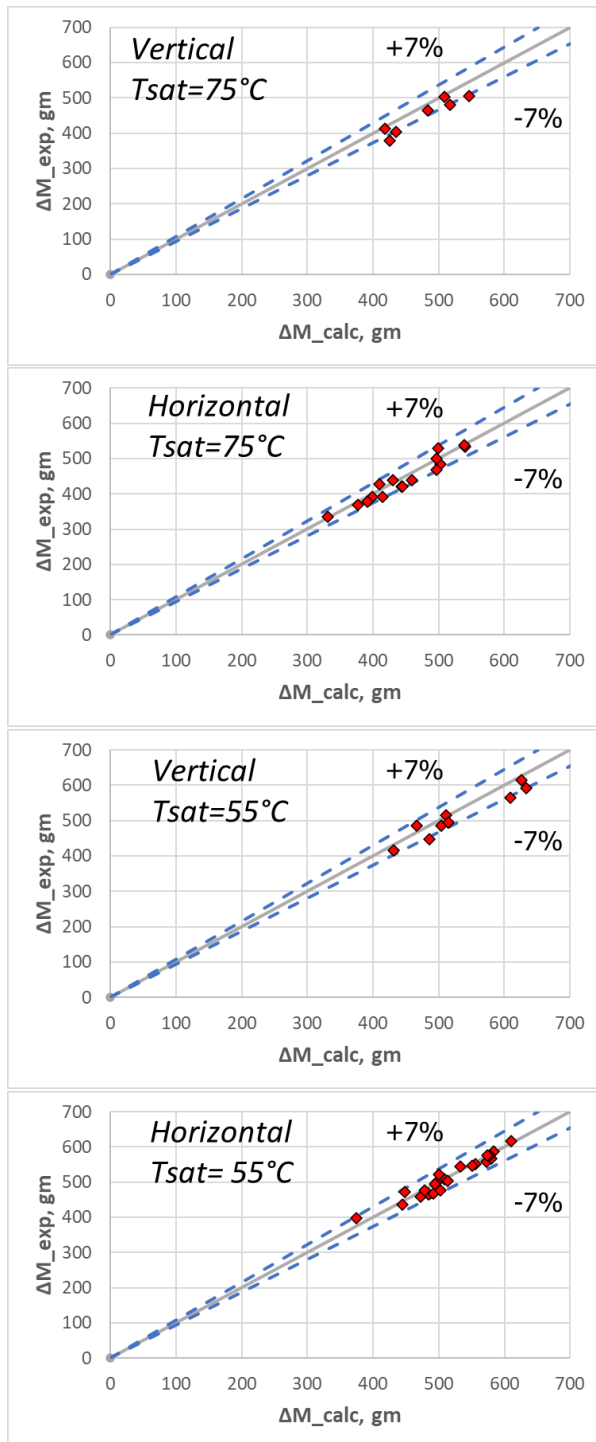

Fig. 3. Comparison of calculated and experimental changes in mass in the loop in single-phase and two-phase modes. Chisholm correlation is used

Table 1

RMS value for different models

	Horizontal		Vertical	
	55	75	55	75
T sat, °C				
Homogeneous	0.135	0.163	0.197	0.219
Momentum flux	0.156	0.153	0.088	0.076
Zivi	0.062	0.054	0.049	0.077
Levy	0.065	0.049	0.043	0.073
Chisholm	0.029	0.039	0.052	0.09
Cincinatti	0.073	0.112	0.1	0.168

Conclusions

To maintain the performance of the two-phase mechanically pumped loop of the spacecraft thermal control system at a minimum and maximum heat load, to ensure the possibility of controlling the pressure in the loop over the entire operating range using a heat-controlled accumulator, to minimize the weight of the structure and volume of the heat-controlled accumulator, it is necessary to calculate its required volume correctly.

A method of calculating the required volume of the heat-controlled accumulator is proposed. The calculation accuracy of the accumulator volume is determined mainly by the calculation error of the working fluid mass in the two-phase part of the loop during its operation in the "hot" mode (maximum heat load, the worst heat removal conditions). In addition to considering the real configuration of heat supply and heat removal and vapor quality distribution along the loop, the phase slip factor, which depends on the channel geometry and flow parameters, should be considered in the calculation model. Various models for calculating the phase slip factor have been analyzed (Homogeneous model, Momentum flux model, Zivi model, Levy model, Chisholm model, Cincinatti model). Calculation of fluid mass difference in the loop during single-phase "cold" mode (minimum heat loads, best heat removal conditions) and two-phase "hot" mode was compared with the experiment on the loop model. It was shown that the best coincidence of calculation and experiment takes place when the Chisholm model is used in calculations.

The single-loop experimental setup included all main elements of the standard system: pump, evaporator, two-phase transport section, condenser, and heat-controlled accumulator. The experiments were carried out with natural working fluid (ammonia), at parameters characteristic of two-phase mechanically pumped loops of unmanned spacecraft thermal mode systems, at relatively high flow rates (when gravity does not affect hydrodynamics and heat exchange), at the horizontal and vertical location of the evaporator. This allows us to

recommend using the Chisholm model to calculate phase slip in weightless conditions as well.

References (GOST 7.1 2006)

1. Никонов, А. А. Теплообменные контуры с двухфазным теплоносителем для систем терморегулирования космических аппаратов [Текст] / А. А. Никонов, Г. А. Горбенко, В. Н. Блинков // Ракетно-космическая техника, машиностроение. – М. : ЦНТИ «Поиск», 1991. – 302 с.

2. NASA Technology Roadmaps, TA 14: Thermal Management Systems. – NASA, Washington D.C., July 2015. – 97 p.

3. Bland, T. J. A two-phase thermal management system for the Space Station [Text] / T. J. Bland, R. Downing, D. Rogers // 19th Thermophysics Conference 25 June - 28 June 1984 Snowmass, CO, U.S.A. DOI: 10.2514/6.1984-1758.

4. Myron, D. L. Development of a prototype two-phase thermal bus system for Space Station [Text] / D. L. Myron, R. C. Parish // 22nd Thermophysics Conference 08 June - 10 June 1987, Honolulu, HI, U.S.A. DOI: 10.2514/6.1987-1628.

5. Experimental study on the transient behaviors of mechanically pumped two-phase loop with a novel accumulator for thermal control of space camera payload [Text] / Meng, Qingliang & Zhao, Zhenming & Zhang, T. & Es, Johannes & Pauw, Aswin & Zhang, Huandong & Yan, Yinxue // Applied Thermal Engineering. – 2020. – Vol. 179, Article Id: 115714. DOI: 10.1016/j.applthermaleng.2020.115714

6. Пат. 2117891. Российская Федерация. Устройство для поддержания давления в теплоносителе в контуре системы терморегулирования космического аппарата. [Текст] / Гончаров Б. А., Латышев И. Н., Прохоров Ю. М., Сарычев Л. Н., Семенов А. Н., Федотов В. К., Цихоцкий В. М., Горбенко Г. А. ; заявитель и патентообладатель – ОАО РКК «Энергия» ; приоритет от 12.08.1997. – 17 с.

7. Епифанов, К. С. Идентификация модели теплового гидроаккумулятора контура теплопереноса Российского сегмента Международной космической станции «Альфа» [Текст] / К. С. Епифанов, А. Н. Семенов // Авиационно-космическая техника и технология. – 1999. – Вып. 9. Тепловые двигатели и энергоустановки. – С. 527-533

8. Семенов, А. Н. Моделирование двухфазного контура теплопереноса централизованной системы теплоотвода российского сегмента международной космической станции в условиях космического полета [Текст] : дис. ... канд. техн. наук / Семенов А. Н. – Москва, 2003. – 168 с.

9. Басов, А. А. Двухфазный контур системы обеспечения теплового режима научно-энергетического модуля. Численное моделирование гидравлических характеристик [Текст] / А. А. Басов, М. А. Лексин, Ю. М. Прохоров // Космическая

техника и технологии. – М. : РКК «Энергия», 2017. – No 2 (17). – С. 80-89.

10. Butterworth, D. Two Phase Flow and Heat Transfer [Text] / D. Butterworth, G. F. Hewitt. – Oxford University Press, London, 1977. – P. 58-90.

11. Chisholm, D. Two-phase flow in pipelines and heat exchangers [Text] / D. Chisholm. – London : G. Godwin in association with Institution of Chemical Engineers, 1983. – 304 p.

12. Zivi, S. M. Estimation of Steady-State Steam Void-Fraction by Means of the Principle of Minimum Entropy Production [Text] / S. M. Zivi // Journal of Heat Transfer. – 1964. – Vol. 86, no. 2. – P. 247-251. DOI: 10.1115/1.3687113.

13. Levy, S. Steam Slip–Theoretical Prediction From Momentum Model [Text] / S. Levy // Journal of Heat Transfer. – 1960. – Vol. 82, no. 2. – P. 113–124. DOI: 10.1115/1.3679890.

14. Chisholm, D. An equation for velocity ratio in two-phase flow [Text] / D. Chisholm // NEL Report No. 535. – East Kilbride, Glasgow, 1972.

15. Narcy, M. Flow boiling in tube under normal gravity and microgravity conditions [Text] / Marine Narcy, Erik de Malmazet, Catherine Colin // International Journal of Multiphase Flow. – 2014. – Vol. 60. – P. 50–63. DOI: 10.1016/j.ijmultiphaseflow.2013.11.011.

References (BSI)

1. Nikonov, A. A., Gorbenko, G. A., Blinkov, V. N. Teploobmennye kontury s dvukhfaznym teplonositelem dlya sistem termoregulirovaniya kosmicheskikh apparatov [Heat-exchange loops with a two-phase coolant for spacecraft thermal control systems]. Raketnokosmicheskaya tekhnika, mashinostroenie, Moscow, TsNTI «Poisk» Publ., 1991. 302 p

2. NASA Technology Roadmaps, TA 14: Thermal Management Systems. NASA, Washington D.C., July 2015. 97 p.

3. Bland, T. J., Downing, R. S., Rogers, D. P. A two-phase thermal management system for large space platforms. 19th Thermophysics Conference 25 June - 28 June 1984 Snowmass, CO, U.S.A. DOI: 10.2514/6.1984-1758.

4. Myron, D. L., Parish, R. C. Development of a prototype two-phase thermal bus system for Space Station. 22nd Thermophysics Conference 08 June - 10 June 1987, Honolulu, HI, U.S.A. DOI: 10.2514/6.1987-1628.

5. Meng, Q. et al. Experimental study on the transient behaviors of mechanically pumped two-phase loop with a novel accumulator for thermal control of space camera payload. Applied Thermal Engineering, 2020, vol. 179, article id: 115714. DOI: 10.1016/j.applthermaleng.2020.115714

6. Goncharov, B. A., Latyshev, I. N., Prokhorov, Yu. M., Sarychev, L. N., Sementsov, A. N., Fedotov, V. K., Tsikhotskii, V. M., Gorbenko, G. A. Ustroistvo dlya podderzhaniya davleniya v teplonositele v konture sistemy termoregulirovaniya kosmicheskogo apparata

[Device for maintaining pressure in the loop coolant of thermal control system of space vehicle]. Patent RF, no. 2117891, 1998. 17 p.

7. Epifanov, K. S., Semencov, A. N. Identifikatsiya modeli teplovogo gidroakkumulyatora kontura teploperenosa Rossiyskogo segmenta Mezhdunarodnoy kosmicheskoy stantsii «Alfa» [Identification of the model of heat controlled accumulator of the heat transfer loop of the Russian segment of the International Space Station "Alpha"]. *Aviatsijno-kosmichna tehnika i tehnologia – Aerospace technic and technology*, 1999, vol. 9, pp. 527-533.

8. Semencov, A. N. *Modelirovanie dvuhfaznogo kontura teploperenosa tsentralizovannoy sistenyi teplootvoda rossiyskogo segmenta mezhdunarodnoy kosmicheskoy stantsii v usloviyah kosmicheskogo poleta*. Diss. Dokt. Tehn. nauk [Sumulation of two-phase heat transfer loop of a centralized heat removal system Doc. Diss.]. Moscow, 2003. 168 p.

9. Basov, A. A., Leksin, M. A., Prokhorov, Yu. M. *Dvukhfaznyy kontur sistemy obespecheniya teplovogo rezhima nauchno-energeticheskogo modulya. Chislennoye modelirovaniye gidravlicheskikh kharakteristik* [A two-phase loop of thermal control system of science-power module. Numerical simulation of hydraulic char-

acteristics]. *Space technique and technology*, Moscow, RSC Energia Publ., 2017, no. 2 (17), pp. 80-89.

10. Butterworth, D., Hewitt, G. F. *Two Phase Flow and Heat Transfer, Ch. 4, Empirical Methods for Pressure Drop*. London, Oxford University Press, 1977, pp. 58-90.

11. Chisholm, D. *Two-phase flow in pipelines and heat exchangers*. London, G. Godwin in association with Institution of Chemical Engineers, 1983. 304 p.

12. Zivi, S. M. Estimation of Steady-State Steam Void-Fraction by Means of the Principle of Minimum Entropy Production. *Journal of Heat Transfer*, 1964, vol. 86, no. 2, pp. 247-251. DOI: 10.1115/1.3687113

13. Levy, S. Steam Slip—Theoretical Prediction From Momentum Model. *Journal of Heat Transfer*, 1960, vol. 82, no. 2, pp. 113-124. DOI: 10.1115/1.3679890.

14. Chisholm, D. *An equation for velocity ratio in two-phase flow*. NEL Report No. 535, East Kilbride, Glasgow, 1972.

15. Narcy, M., de Malmazet Erik., Colin, Catherine. Flow boiling in tube under normal gravity and microgravity conditions. *International Journal of Multiphase Flow*, 2014, vol. 60, pp. 50-63. DOI: 10.1016/j.ijmultiphaseflow.2013.11.011.

Надійшла до редакції 27.01.2021, розглянута на редколегії 23.09.2021

РОЗРАХУНОК ОБСЯГУ ГІДРОАКУМУЛЯТОРА ДВОФАЗНОГО КОНТУРУ ТЕПЛОПЕРЕНОСУ СИСТЕМИ ТЕРМОРЕГУЛЮВАННЯ КОСМІЧНОГО АПАРАТУ

А. М. Годунов, Г. О. Горбенко, П. Г. Гакал

Системи терморегулювання космічних апаратів на базі двофазних контурів теплопереносу мають переваги по масі і енергоспоживанню на власні потреби в порівнянні з однофазними системами терморегулювання. Однак, недоліком двофазних контурів теплопереносу є те, що при зміні теплового навантаження і умов тепловідведення, при переході від однофазного до двофазного режиму роботи і навпаки, кількість теплоносія в контурі істотно змінюється, що вимагає використання гідроаккумулятора великого обсягу. Тому, визначення мінімально необхідного для роботи контуру обсягу гідроаккумулятора є актуальним завданням з огляду на необхідність збереження працездатності контуру при мінімальних і максимальних теплових навантаженнях і мінімізації маси конструкції і заправленого теплоносія. При визначенні обсягу гідроаккумулятора необхідно коректно розраховувати масу теплоносія в контурі теплопереносу на двофазному режимі роботи. Маса теплоносія залежить від об'ємного паровмісту, який істотно залежить від ковзання фаз. Запропоновано багато моделей і кореляцій для розрахунку ковзання фаз. Однак, всі вони вимагають обґрунтування для параметрів, характерних для систем терморегулювання космічних апаратів і умов невагомості. У статті представлені результати наземних експериментів, на основі яких проводилася верифікація різних моделей і кореляцій для ковзання фаз. Обґрунтування застосовності моделей і кореляцій для умов невагомості проводилася шляхом порівняння результатів при горизонтальній і вертикальній орієнтації елементів експериментальної установки. Теплоносій-аміак. Експерименти показали, що найкращий збіг розрахунку і досвіду забезпечує кореляція Chisholm. Розбіжність між розрахунковим і експериментальним значеннями не перевищувала +/-7% у всьому діапазоні досліджених параметрів як для горизонтальної, так і для вертикальної орієнтації, що дозволяє рекомендувати кореляцію Chisholm для визначення маси теплоносія в двофазному контурі теплопереносу для параметрів, характерних для систем терморегулювання космічних апаратів, в тому числі і для умов невагомості.

Ключові слова: космічний апарат; невагомість; система терморегулювання; двофазний контур теплопереносу; гідроаккумулятор з тепловим регулюванням; об'єм; аміак; ковзання фаз.

**РАСЧЕТ ОБЪЕМА ГИДРОАККУМУЛЯТОРА
ДВУХФАЗНОГО КОНТУРА ТЕПЛОПЕРЕНОСА
СИСТЕМЫ ТЕРМОРЕГУЛИРОВАНИЯ КОСМИЧЕСКОГО АППАРАТА**

А. М. Годунов, Г. А. Горбенко, П. Г. Гакал

Системы терморегулирования космических аппаратов на базе двухфазных контуров теплопереноса обладают преимуществами по массе и энергопотреблению на собственные нужды по сравнению с однофазными системами терморегулирования. Однако, недостатком двухфазных контуров теплопереноса является то, что при изменении тепловой нагрузки и условий теплоотвода, при переходе от однофазного к двухфазному режиму работы и наоборот, количество теплоносителя в контуре существенно изменяется, что требует использования гидроаккумулятора большого объема. Поэтому, определение минимально необходимого для работы контура объема гидроаккумулятора является актуальной задачей ввиду необходимости сохранения работоспособности контура при минимальных и максимальных тепловых нагрузках и минимизации массы конструкции и заправленного теплоносителя. При определении объема гидроаккумулятора необходимо корректно рассчитывать массу теплоносителя в контуре теплопереноса на двухфазном режиме работы. Масса теплоносителя зависит от объемного паросодержания, которое существенно зависит от скольжения фаз. Предложено много моделей и корреляций для расчета скольжения фаз. Однако, все они требуют обоснования для параметров, характерных для систем терморегулирования космических аппаратов и условий невесомости. В статье представлены результаты наземных экспериментов, на основе которых проводилась верификация различных моделей и корреляций для скольжения фаз. Обоснование применимости моделей и корреляций для условий невесомости проводилась путем сравнения результатов при горизонтальной и вертикальной ориентации элементов экспериментальной установки. Теплоноситель – аммиак. Эксперименты показали, что наилучшее совпадение расчета и опыта обеспечивает корреляция Chisholm. Расхождение между расчетным и экспериментальным значениями не превышало +/-7% во всем диапазоне исследованных параметров как для горизонтальной, так и для вертикальной ориентации, что позволяет рекомендовать корреляцию Chisholm для определения массы теплоносителя в двухфазном контуре теплопереноса для параметров, характерных для систем терморегулирования космических аппаратов, в том числе и для условий невесомости.

Ключевые слова: космический аппарат; невесомость; система терморегулирования; двухфазный контур теплопереноса; гидроаккумулятор с тепловым регулированием; объем; аммиак; скольжение фаз.

Годунов Артем Михайлович – асп. каф. аэрокосмической теплотехники, Национальный аэрокосмический университет им. Н. Е. Жуковского «Харьковский авиационный институт», Харьков, Украина.

Горбенко Геннадий Александрович – д-р техн. наук, проф., проф. каф. аэрокосмической теплотехники, Национальный аэрокосмический университет им. Н. Е. Жуковского «Харьковский авиационный институт», Харьков, Украина.

Гакал Павел Григорьевич – д-р техн. наук, доцент, зав. каф. аэрокосмической теплотехники, Национальный аэрокосмический университет им. Н. Е. Жуковского «Харьковский авиационный институт», Харьков, Украина.

Artem Hodunov – PhD student of Dep. of Aerospace Heat Engineering, National Aerospace University «Kharkov Aviation Institute», Kharkov, Ukraine,
e-mail: artem.hodunov@ctph.com.ua, ORCID: 0000-0001-8850-8367.

Gennady Gorbenko – Doctor of Technical Sciences, Professor of Dep. of Aerospace Heat Engineering, National Aerospace University «Kharkiv Aviation Institute», Kharkiv, Ukraine,
e-mail: gennadiy.gorbenko@ctph.com.ua.

Pavel Gakal – Doctor of Technical Sciences, Assistant Professor, Head of Department of Aerospace Heat Engineering, National Aerospace University «Kharkiv Aviation Institute», Kharkiv, Ukraine,
e-mail: p.gakal@khai.edu, ORCID: 0000-0003-3043-2448.