

MINISTRY OF EDUCATION AND SCIENCE OF UKRAINE

National Aerospace University
«Kharkov Aviation Institute»

I. Kravchenko, S. Yepifanov, A. Garkusha

AIRCRAFT PROPELLERS

Tutorial

Kharkov «KhAI» 2020

UDC 629.735.33.026.55(075.8)

K-78

Стисло викладено загальні відомості про повітряні гвинти. Розглянуто геометричні й кінематичні характеристики гвинта, тягу, потужність, ККД гвинта, режими роботи гвинта, силовий вплив на лопаті гвинта. Викладено основні відомості про будову і конструкцію втулок гвинтів змінного кроку, їх окремих вузлів. Наведено основні дані серійних зразків повітряних гвинтів, описано їх конструкцію.

Для англomовних студентів, які вивчають курс «Конструкція і динаміка авіаційних двигунів і енергетичних установок».

Reviewers: Doctor of Science, Professor A. Kachan,
Candidate of Science, Associate Professor A. Litviak

Kravchenko, I.

K-78 Aircraft propellers [Text] : tutorial / I. Kravchenko, S. Yepifanov, A. Garkusha. – Kharkiv : National Aerospace University «Kharkiv Aviation Institute», 2020. – 64 p.

ISBN 978-966-662-724-0

The manual deals with the aircraft propeller overview. It contains the geometrical and kinematic performances of propeller and its thrust, power, efficiency, operational modes, forces and moments acting on its blades. The manual also deals with the arrangement and the construction of the variable-pitch propeller hubs and their units. The manual also has the characteristics and the description of the mass-produced propellers.

The manual will be interesting for the students studying «Design and Dynamics of aircraft engines and power plants».

Fig. 35. Bibliogr.: 8 items.

UDC 629.735.33.026.55(075.8)

© Kravchenko I., Yepifanov S.,
Garkusha A., 2020

© National Aerospace University
«Kharkiv Aviation Institute», 2020

ISBN 978-966-662-724-0

CONTENT

NOMENCLATURE	5
1. MAIN PARAMETERS AND OPERATING CONDITIONS OF AIRCRAFT	
PROPELLERS	6
1.1. General.....	6
1.2. Main geometric and kinematic parameters	7
1.3. Thrust, power and efficiency	9
1.4. Operating modes	11
1.5. Forces and moments acting on propeller blades.....	12
1.5.1. Centrifugal force acting on the blades	13
1.5.2. Moment of centrifugal force	13
1.5.3. Aerodynamic forces and moments	14
1.5.4. Centrifugal forces of counterweights	15
2. CLASSIFICATION OF AIRCRAFT PROPELLERS.....	15
3. NEGATIVE THRUST AND PROTECTIVE MEASURES.....	20
3.1. Conditions of negative thrust in-flight origination.....	20
3.2. Protective measures	21
3.2.1. Pitch stops	21
3.2.2. Intermediate stop	23
3.2.3. Feathering.....	25
4. HUBS OF VARIABLE PITCH PROPELLERS.....	26
4.1. Blades turning by hubs of different schemes.....	26
4.2. Construction of main elements of VPP hub.....	28
4.3. Add-on devices of VPP hub	32
4.3.1. Hydraulic pitch stop	33
4.3.2. Mechanical pitch stop.....	33
4.3.3. Centrifugal pitch stop	34
4.3.4. Intermediate stop	35
4.3.5. Ice protection system	35

5. AIRCRAFT PROPELLER AV-60	37
5.1. General.....	37
5.2. Construction	38
5.2.1. Front propeller hub.....	38
5.2.2. Rear propeller hub	42
5.3. Propeller blades.....	43
5.4. Ice protection system.....	43
6. AIRCRAFT PROPELLER AV-68I	45
6.1. General.....	45
6.2. Construction	46
6.2.1. Propeller hub.....	46
6.3. Blades	50
6.4. Ice protection system.....	50
7. AIRCRAFT PROPELLER AV-140	51
7.1. General.....	51
7.2. Construction	52
7.2.1. Unit of propeller hub.....	52
7.3. Blades	55
7.4. Ice protection system.....	55
CHECK QUESTIONS	56
GLOSSARY ON AIR PROPELLERS	57
BIBLIOGRAPHY	62

NOMENCLATURE

AC	– alternating current;
<i>b</i>	– chord;
C_R	– aerodynamic force factor;
CPS	– centrifugal pitch stop;
<i>D</i>	– blade diameter;
G_f	– fuel consumption;
<i>H</i>	– geometric pitch;
H_a	– effective pitch (advance);
HPS	– hydraulic pitch stop;
<i>i</i>	– number of blades;
<i>M</i>	– moment; Mach number;
M_a	– moment of aerodynamic forces;
M_c	– moment of centrifugal forces;
M_{CW}	– moment of counterweight centrifugal force;
$M_{w 1}$	– Mach number for relative velocity;
MPS	– mechanical pitch stop;
<i>m</i>	– mass;
N_p	– power of propeller;
<i>n</i>	– rotor rotational speed;
n_{max}	– maximum rotor rotational speed;
n_s	– second rotational speed;
<i>P</i>	– thrust;
P_c	– centrifugal force;
P_{CW}	– centrifugal force of counterweight;
p_{oil}	– oil command pressure;
p_{drain}	– oil drain pressure;
<i>R</i>	– aerodynamic force; radius;
<i>r</i>	– radius;
<i>Q</i>	– drag;
<i>u</i>	– circumferential velocity;
VPP	– variable pitch propeller;
v_f	– flight velocity;
w_1	– relative velocity;
α	– attack angle;
$\bar{\alpha}$	– specific coefficient of thrust;
β	– inflow angle;
$\bar{\beta}$	– specific coefficient of power;
η	– efficiency;
φ	– blade stagger angle;
φ_f	– feathering angle;
φ_{IS}	– intermediate stop angle;
φ_{min}	– minimum blade angle;
φ_{PS}	– pitch stop angle;
φ_{rev}	– blade reversing position;
φ_0	– blade starting angle;
λ	– slip function;
ω	– total induced velocity; angular velocity;
ρ	– density.

1. MAIN PARAMETERS AND OPERATING CONDITIONS OF AIRCRAFT PROPELLERS

1.1. General

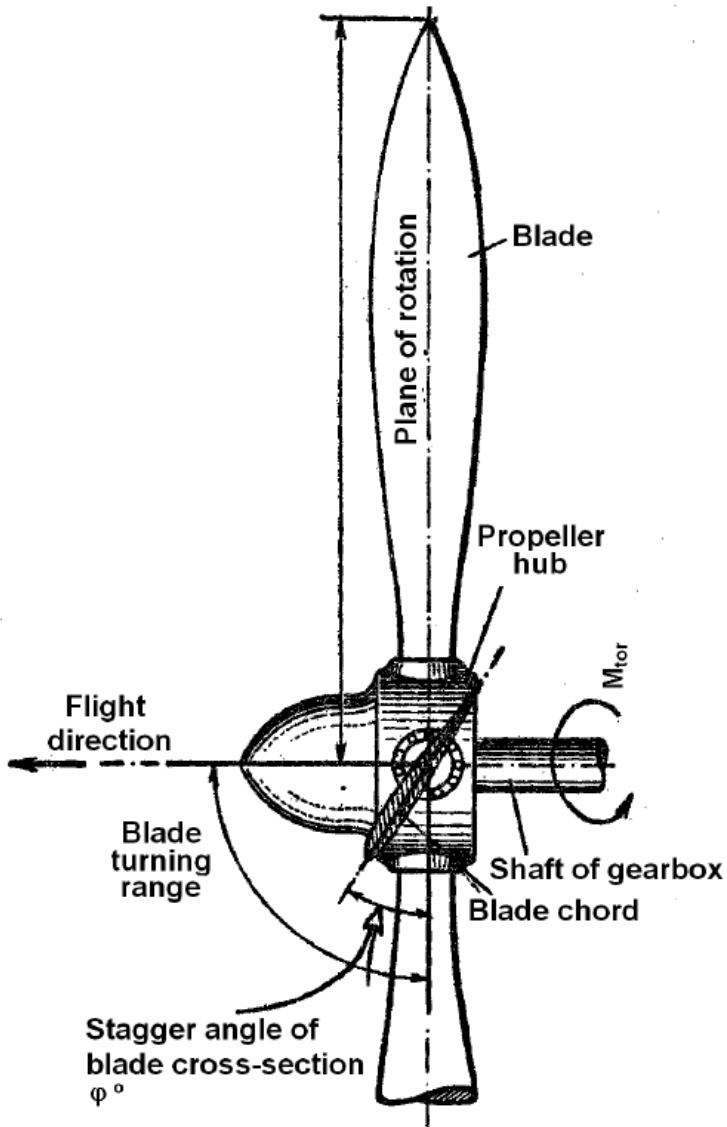

Fig. 1.1. Aircraft propeller

Aircraft propeller (airscrew) is a component of the power plant, which produces thrust by putting the airflow off.

The propeller consists of two or more blades and a bladed central hub. Propeller hub is rigidly joined to a shaft (Fig. 1.1). Each blade has analogy to a rotating wing. Same to the wing, the propeller blades produce forces, which total is thrust force.

The propeller is powered by the engine. The high-power engines have their propeller mounted on a propeller shaft that is geared to the engine output shaft via the gearbox.

Requirements for the aircraft propellers are:

- high efficiency;
- automatic correction of a stagger angle on flight conditions and engine operating mode;
- wide range of stagger angle (usually $0...90^\circ$);

- high angular velocity of blades turning;
- minimum reaction and gyroscopic moments;
- no negative thrust within entire range of probable flight conditions;
- blades and hub cowl ice protection;
- minimum acoustic and vibration loading of an aircraft;
- minimum mass;
- easy manufacturing, maintenance and overhaul.

1.2. Main geometric and kinematic parameters

The propeller consists of similar blades symmetrically joined to propeller hub. The propeller hub joins the airscrew to the engine or gearbox shaft.

The main parameters characterizing the propeller overall size are **diameter D** (Fig. 1.2) and **blade chord b** (usually the chord depends on rotation radius).

The blade angle φ of a particular section can be understood as the angle between the chord of this section and a plane of rotation (Fig. 1.3). To make the attack angle similar in all cross-sections, the blade angle must be reduced with the radius. Therefore, let us introduce a new term **stagger angle φ** to compare blade positions. The stagger angle is equal to a stagger angle of the **blade control cross-section**. The cross-section appears on the 0.75 of the airscrew radius. For the airscrews, which diameter is greater than 4 m, control cross-section is chosen at radius 1600 mm. The blade control cross-section is indicated by a red strip.

In flight, each cross-section of a blade rotates being actuated by the shaft and simultaneously moves forward with the aircraft. If this motion appears to be in a rigid substance (for example the propeller is screwed into a specially profiled nut), then the propeller (blade angle φ at radius r) will cover per one revolution a distance that is named **geometric pitch** (see Fig. 1.2)

$$H = 2\pi r \operatorname{tg}\varphi. \quad (1.1)$$

In fact, the propeller rotates in the elastic, compressible and compliant air. Therefore, the distance

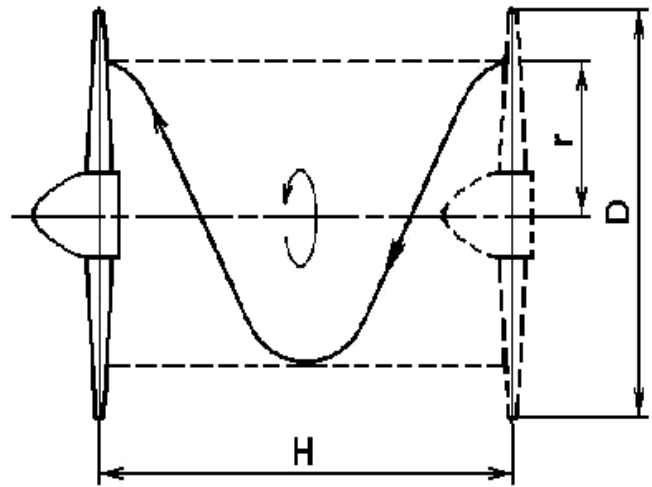

Fig. 1.2. Diameter and geometric pitch of airscrew

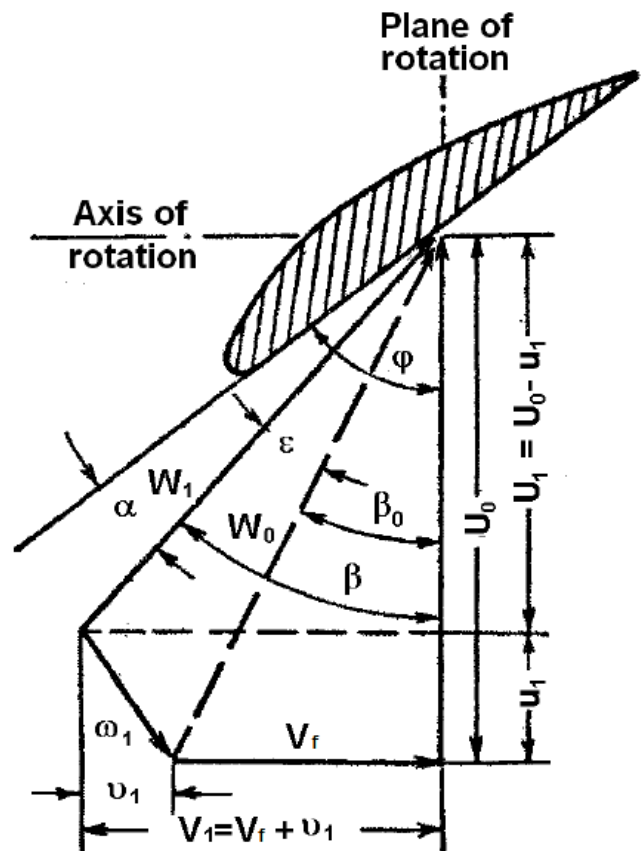

Fig. 1.3. Polygon of velocities at a blade cross-section

covered by the airscrew per a revolution is different from the geometric pitch. This distance is termed as **effective pitch (advance)**

$$H_a = \frac{v_f}{n_s}, \quad (1.2)$$

where v_f is a flight velocity, m/s;

n_s is a secondary rotational speed of the airscrew, rps.

Slip is defined as the difference between the geometric and effective pitch. It may be expressed as the percentage of the mean geometric pitch. The specific slip (**slip function**) λ is more handy in designing and numerical analysis:

$$\lambda = \frac{H_a}{D} = \frac{v_f}{n_s D}. \quad (1.3)$$

Fig. 1.3 represents a section of the blade and velocities that describe the motion of the blade and air. In flight, the blade section moves at circumferential velocity of u_o and translation velocity of v_f . In addition to the mentioned velocities, an induced velocity of suction v_1 (axial) and slip u_1 appear in the plane of rotation. Total induced velocity is equal to $w_1 = \sqrt{v_1^2 + u_1^2}$.

Resultant velocity of the air in relation to the blade cross-section

$$w_1 = \sqrt{(v_f + v_1)^2 + (u_o - u_1)^2}.$$

The angle between w_1 and the chord is termed an **attack angle** α . The angle between w_1 and the pitch velocity is termed **inflow angle** β .

At some distance upstream a propeller (Fig. 1.4), the translation in jet is equal to a flight velocity. This velocity is usually named as a velocity of undisturbed flow and is designated as v_f .

Blades interact with air, creating a low-pressure zone right upstream the plane of rotation, thus accelerating the airflow in this zone.

The flow velocity increases on v_1 , so the relative velocity in the plane of rotation is

$$V_1 = v_f + v_1.$$

At some distance downstream the propeller that is approximately equal to a half of diameter, the flow accelerates to

$$V_2 = v_f + v_2.$$

It was theoretically deduced and experimentally validated that

$$v_1 = v_2 / 2.$$

A funnel-shaped air stream originates near the propeller (see Fig. 1.4); cross-section of this stream may be determined using formula of the airflow rate. Airflow rates are equal at all sections of a stream. So, the greater the air velocity is, the less the sectional area is. Usually, the compression of the stream comes to its end at the distance equal to a half of the airscrew diameter.

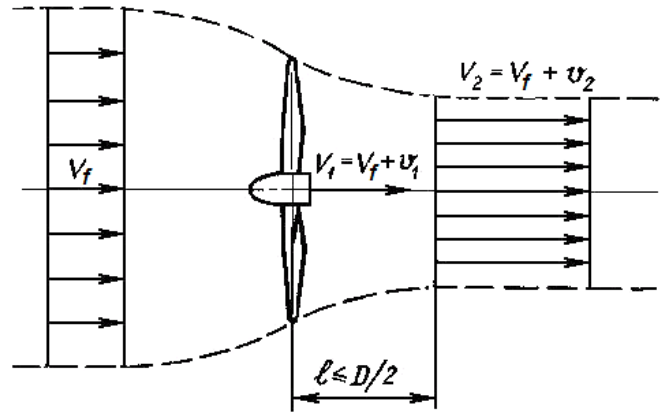

Fig. 1.4. Flow profile near propeller

As the propeller acts on a flow, then, according to the third Newton`s law, the flow oppositely reacts on the propeller blades. This interaction is analogical to that between the air and wing of airplane. But the interaction between the air and the propeller is some more complicated, as different cross-sections of the blade operate at different conditions (different pitch and relative airflow velocities, relative thickness of an airfoil and inflow angle).

1.3. Thrust, power and efficiency

The aerodynamic force acting on an element limited by the radiuses r and $r + dr$ (Fig. 1.5) is evaluated as

$$dR = C_R \frac{\rho w_1^2}{2} b dr ,$$

where C_R is an aerodynamic force factor that depends on airfoil shape and the attack angle.

Projections of aerodynamic force dR on the axis and plane of rotation form thrust dP and drag dQ . Power that the propeller consumes from the engine is spent for the drag overcoming. A drag moment is $dM = dQ r$. Hence, the required power to drive the propeller is

$$dN = dM \omega = dQ r \omega.$$

Thrust and **power** of the airscrew are determined by integrating elementary thrust and power:

$$P = i \int_{r_0}^R dP; N_p = i \int_{r_0}^R r \omega dQ, \quad (1.4)$$

where i is the number of blades.

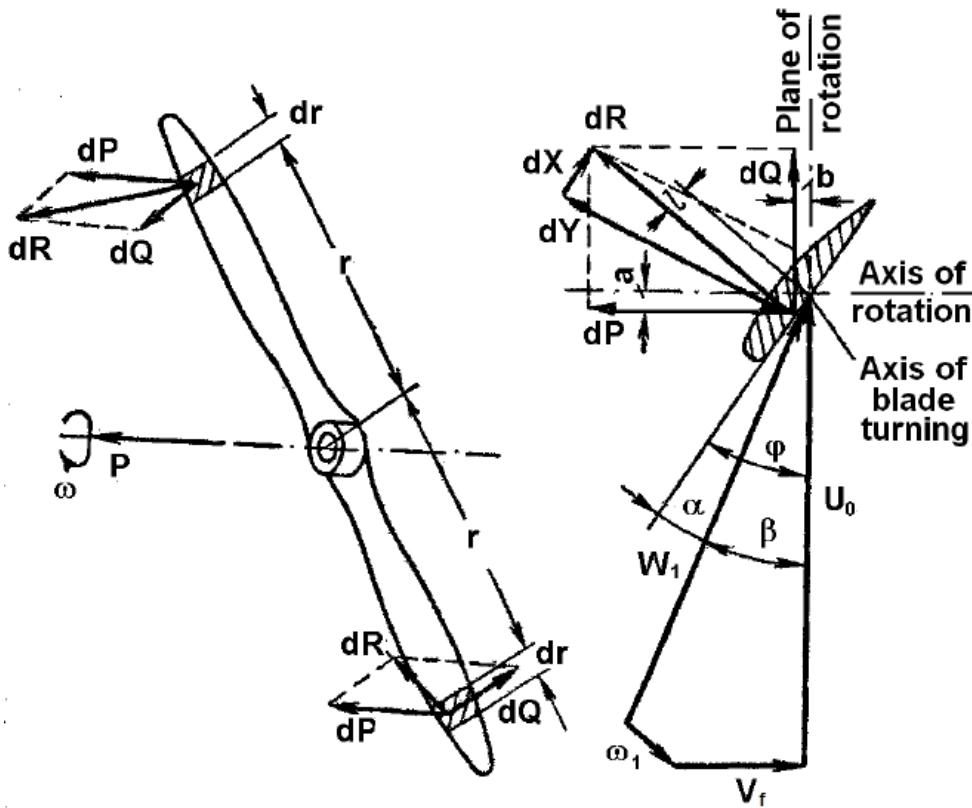

Fig. 1.5. Aerodynamic forces acting a blade element

According to the theory of aerodynamic similarity, the thrust and needed power of propeller are determined as

$$P = \bar{\alpha} \rho n_s^2 D^4; N_p = \bar{\beta} \rho n_s^3 D^5, \quad (1.5)$$

where $\bar{\alpha}$ and $\bar{\beta}$ are specific coefficients of thrust and power that depend on a propeller shape and the operating conditions (the latter are characterized by a specific advance λ).

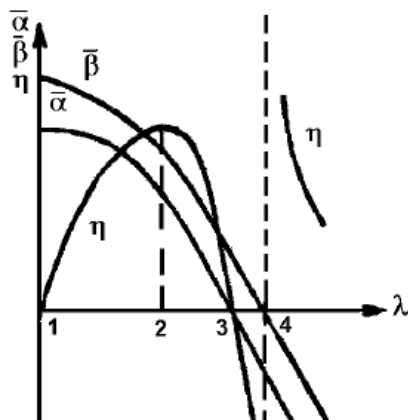

Fig. 1.6. Aerodynamic performances of propeller at constant blade angle

The induced power of propeller is the product of the thrust and the aircraft velocity; therefore, **efficiency of propeller is**

$$\eta = \frac{P v_f}{N_p} = \frac{\bar{\alpha} \rho n_s^2 D^4 v_f}{\bar{\beta} \rho n_s^3 D^5} = \frac{\bar{\alpha} v_f}{\bar{\beta} n_s D} = \frac{\bar{\alpha}}{\bar{\beta}} \lambda. \quad (1.6)$$

Coefficients $\bar{\alpha}$, $\bar{\beta}$, efficiency and advance are essential for propeller design. Their relation at constant blade angle is shown in Fig. 1.6.

1.4. Operating modes

Let us consider the propeller with known dimensions that rotates with constant speed in the atmosphere of the constant density. In these conditions, the flight velocity is the only parameter that influences the thrust and the needed power.

The dependences of thrust, needed power and efficiency on the flight velocity is shown in Fig. 1.7. It illustrates the main characteristic operating modes of the propeller.

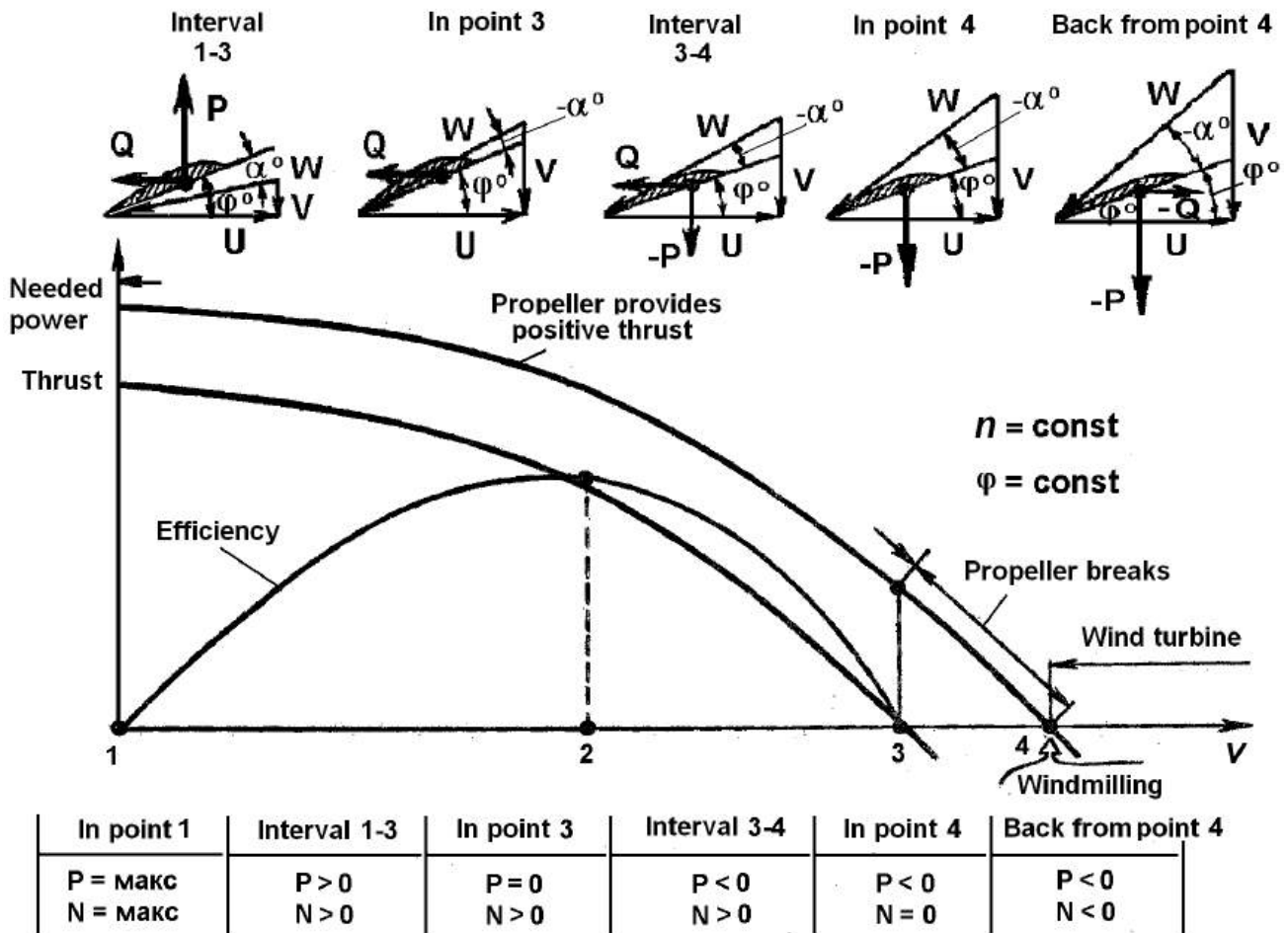

Fig. 1.7. N_p , P and η vs flight velocity at constant rotation speed and constant blade angle

Running in place. The needed power to rotate the propeller and thrust reach the maximum values at the running in ($v_f = 0$, point 1 in Fig. 1.7). The attack angle α is approximately equal to the blade angle φ . Following the formula (1.6) for zero flight velocity, the efficiency of the propeller turns zero.

Propelling (see p. 2 in Fig. 1.7) is the mode at which $v_f > 0$, $P > 0$, $N_p > 0$. Fig. 1.3 shows that the attack angle will decrease if v_f

decreases. Herewith, the efficiency increases, the thrust and the consumed power sink?

The attack angle becomes optimal and propeller efficiency gains its peak.

At further increasing of the flight velocity, thrust, power, and efficiency continue to decrease.

The propelling mode is the main operating mode of the propeller. It is limited with the points 1 and 3. This mode is used during taxiing, takeoff, climbing, cruising and, partially, descending and landing.

Zero-thrust corresponds to the point 3 ($P = 0, N_p > 0$). At this mode, the propeller seems to freely screw into the air, neither pushing it back nor breaking it. This mode is switched on upon airplane gliding. The attack angle at this mode is some less than zero.

Breaking is the mode with the positive power, but negative thrust ($P < 0, N_p > 0$). In Fig. 1.7, the breaking mode finds itself between the points 3 and 4. At this mode, the influent angle β is greater than the blade angle φ (see Fig. 1.3), and the attack angle α is negative. Consequently, thrust and efficiency are negative. *This mode is used to produce the negative (reverse) thrust at landing.*

Windmilling corresponds to the point 4 ($P < 0, N_p = 0$). As the consumed power is zero, the propeller rotates due to the incoming flow (by aerodynamic forces acting on blades) that overcomes internal forces and drag moments.

Wind turbine (on the right from point 4) is the mode with negative power. The propeller rotates driven by the incoming airflow. This mode is used in single-spool turboprops for the in-flight starting. In this case, rotor accelerates to the ignition rotational speed without any starter. Right after aircraft touches down the land, it starts the breaking run, passing through all modes starting from the wind turbine to the zero thrust.

1.5. Forces and moments acting on propeller blades

The forces acting on a propeller in flight are:

- **Thrust.** The thrust vector is parallel to the flight vector. It generates bending of the propeller;
- **Centrifugal force**, which is caused by the rotation. It is about to uproot the blade from the hub. This force generates the tensile stress and the torsional stress;
- **Drag** (air resistance to rotation), which generates the bend of the propeller blades to the hand opposite to rotation hand;
- **Torsion** (twisting) in the blade itself. It is caused by the fact that the resultant aerodynamic force direction is off the neutral axis of the blade, producing torsional stress.

1.5.1. Centrifugal force acting on the blades

Centrifugal forces act on the elements of mass dm of rotating blades (Fig. 1.8):

$$dP_c = \omega^2 r dm = \rho \omega^2 s r dr, \quad (1.7)$$

where ρ – density; r , s – radius and area of blade section.

The centrifugal force acting on the airfoil (from the root radius r_0 to the tip radius R) is determined as the sum of all elementary forces:

$$P_c = \rho \omega^2 \int_{r_0}^R s r dr. \quad (1.8)$$

The centrifugal forces of modern propellers reach tens of tons, perceived by the casing of the hub.

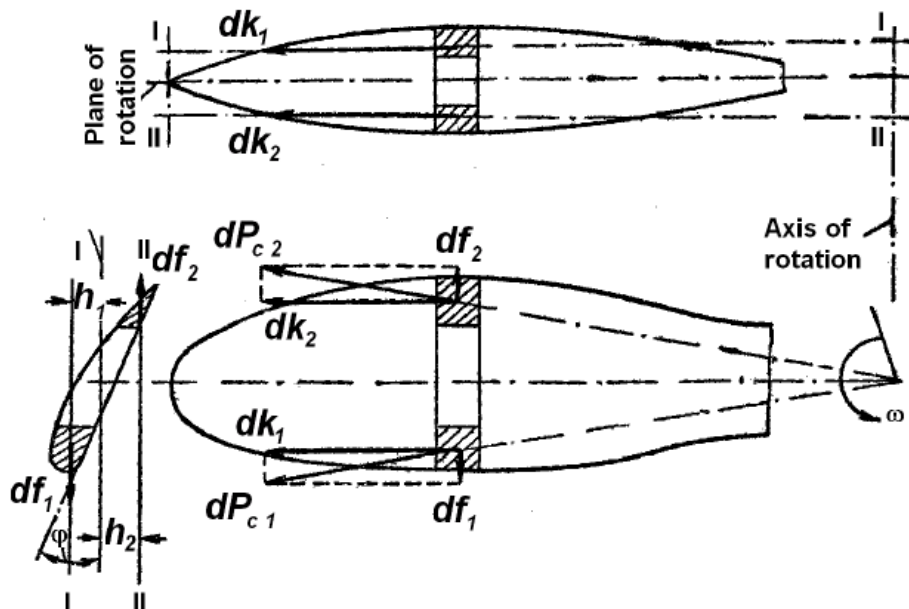

Fig. 1.8. Action of centrifugal forces of blade element

1.5.2. Moment of centrifugal force

Centrifugal forces of separate blade elements are distributed as along the width, so along the height; they form the torsion torque acting on the blade.

Fig. 1.8 shows two elements of the blade, placed between sections with radiuses r and $r + dr$. Vectors of centrifugal forces dP_{c1} and dP_{c2} of the elements belong to a common plane that is perpendicular to the axis of rotation. They may be decomposed into two components: parallel (dk_1 , dk_2) and perpendicular (df_1 , df_2) to the axis of blade.

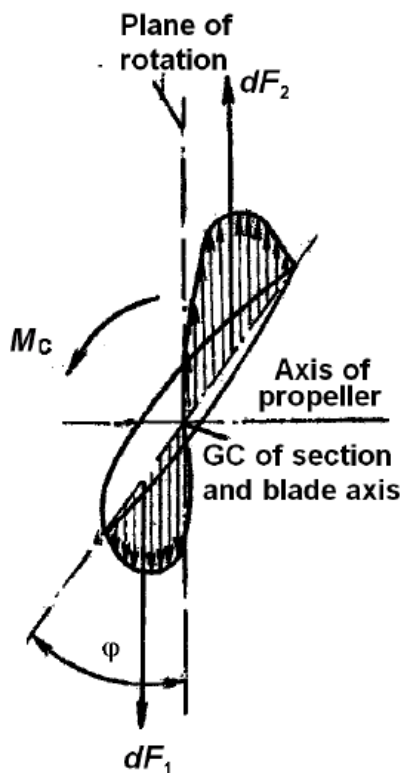

Fig. 1.9. Diagram of transversal components of centrifugal forces in blade section

Having applied such decomposition to all elements, we obtain the diagram of the perpendicular components. Fig. 1.9 shows that the perpendicular components of centrifugal forces change a sign at transition through the blade axis. It usually coincides with the line of gravity centers of sections. Let us substitute forces that act in each direction by the resultant forces dF_1 and dF_2 . Then the couple of forces will be equivalent to the distributed forces. These forces depend on blade length. The collection of the couples of forces sums up a moment M_c of the transversal components of the centrifugal forces that intend to twist the blade to the lower blade angle side.

The moment M_c depends on material of the blade and its shape (it is characterized with chord, shape of profile, law of twisting) and rotational speed.

1.5.3. Aerodynamic forces and moments

Aerodynamic forces (see Fig. 1.5) are initiated by the airflow acting on the blades. They are distributed on a blade surface and generate bending and torsion moments.

The summed-up force of the aerodynamic forces is applied to the center of pressure. The blade is usually designed to have its center of pressure nearer to the leading edge than the axis of blade turning (see Fig. 1.5). Force dR at arm l or forces dP and dQ at arms a and b respectively generate the torsion moment $dM_a = dR l = dP a + dQ b$ about the axis of blade turning. The moment intends to turn the blade to greater blade angles side. As the arm of force l is small, the moment of aerodynamic forces is smallish.

When the attack angle turns negative, the direction of the resultant force dR is changed making the torsion moment of the aerodynamic forces turn the blade to the smaller blade angles side.

1.5.4. Centrifugal forces of counterweights

The torsion moment of aerodynamic forces is insufficient to turn the blade to the greater blade angles side. Therefore, some variable-pitch propellers have counterweights joined to blade roots (Fig. 1.10).

The counterweight is arranged in relation to the blade in the way to make $P_{CW f}$ generate the torsion moment $M_{CW} = P_{CW f} h$. It intends to turn the blade to greater blade angles side. The counterweight may be fitted on a pressure side of the blade root or on its suction side (dashed line in Fig. 1.10).

Mass and position of the counterweights is chosen to let the joint moment by counterweight mass and aerodynamic force overcome the moment of centrifugal forces, and turn the blade at required rate.

Component $P_{CW k}$ bends the support arm of the counterweight.

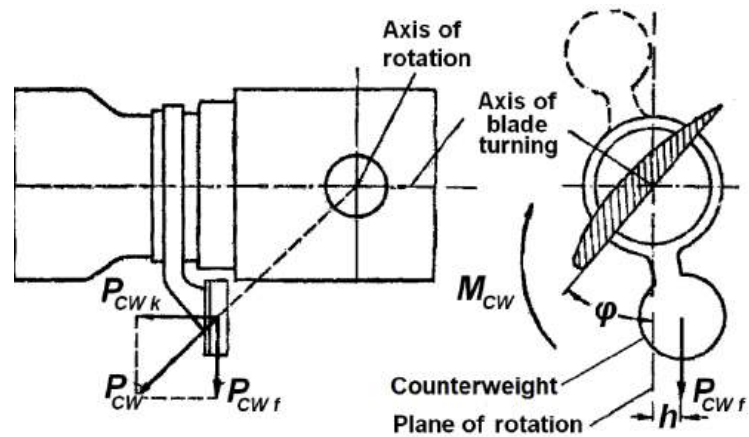

Fig. 1.10. Action of centrifugal forces generated by the counterweight mass

2. CLASSIFICATION OF AIRCRAFT PROPELLERS

Propellers are classified on different features.

1. **On location**, propellers can be tractor and pusher. The **tractor propeller** is ahead of an engine. Most aircraft are equipped with the tractor propeller. The tractor propeller experiences the relatively low stresses as it rotates in the relatively undisturbed airstream, which is undoubtedly an advantage of this propeller type.

The **pusher propeller** is from behind of the engine. Seaplanes and amphibious have pusher propellers more often than other aircraft do.

2. **On presence of in-flight pitch variation**, propellers can be fixed-pitch (FPP) and variable-pitch (VPP). The latest are divided into two-position pitch and automatic pitch (APP) propellers.

The **fixed-pitch propellers** found their use at low flight velocities (for example in motor hang gliders or pilotless vehicles). The engine with the fixed-pitch propeller changes the thrust by the means of rotational speed.

The **two-position pitch propellers** are also efficiently used at low flight velocities. The blade angle can be switched to low-angle setting or a high-angle

setting in flight. A low-angle setting corresponds to takeoff and climbing. After aircraft has gained the necessary altitude, the blades are moved to the high-angle setting for cruising.

The **automatic variable pitch propellers (VPP)** are complex devices with pitch-changing mechanism. This mechanism is governed by the automatic control system, which intends to keep up the set rotational speed.

3. On actuator used for pitch control, propellers can be hydraulic, electromechanical, aeromechanical and mechanical. Hydraulic propellers are the most widespread.

Working fluid of the **hydraulic propellers** is aircraft oil that is used in engine oil systems.

The blades of **electromechanical propellers** are turned by an electric engine. The torque is transmitted through the gearbox with high gear ratio. The electric motor is usually attached to the front part of the propeller hub.

Electric propellers provide an unlimited range of the blade angle variation and automatically fix the blade at its current position in case of electric supply cutoff.

However, the electric propellers are less reliable, more complex and expensive. They have higher mass and lower angular velocity of blades rotation against the hydraulic ones. Therefore, they are not widely used in aviation.

The **aeromechanical propellers** suit the low-power engines. Blades are turned without external power sources and rotational speed governors, just due to the change in torque acting on the blades in flight.

Moments of aerodynamic forces are smallish. However, if the blades are of the special shape and they are tilted at angle γ (Fig. 2.1) to the axis of blade turning, then the position of the gravity center will change, thus increasing the moment of aerodynamic forces turning the blade to greater blade angles side.

Propeller blades are equipped with counterbalance weights. At steady-state modes $M_{CW} = M_c + M_a$. As the flight speed grows higher, the moment

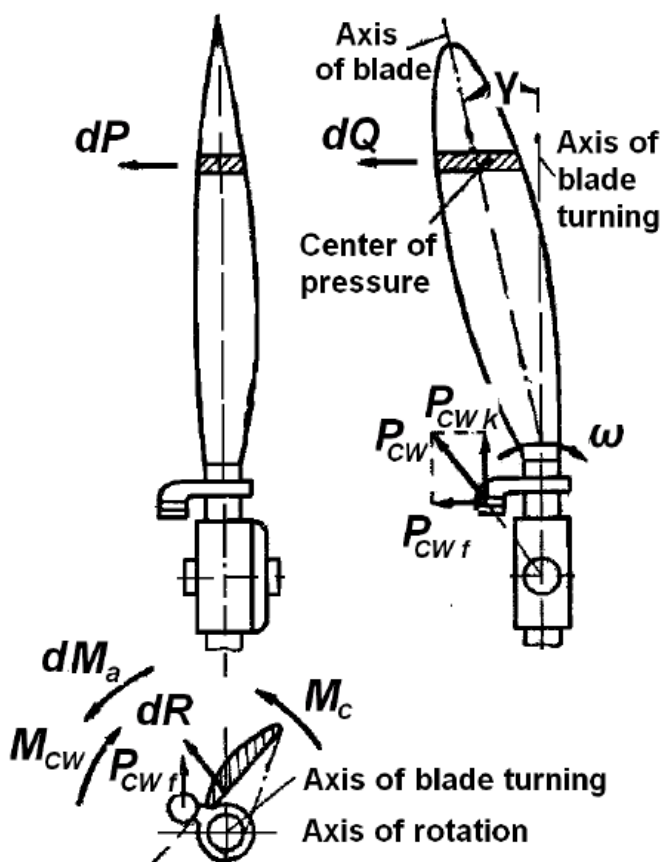

Fig. 2.1. Aeromechanical propeller

of aerodynamic forces increases, thus preventing blade angle from being increased (as it was discussed before, the moments M_{CW} and M_c are flight velocity independent). The rotational speed is some changed, but insignificantly. Thus, the blade angle of aeromechanical propeller automatically alternates with the flight velocity.

Advantages of aeromechanical propellers are simple construction and maintenance, low mass and small size. Disadvantages are:

- when the flight altitude grows, the rotational speed goes down;
- problems in providing the required relation between the moments in a wide range of flight conditions.

Blades of **mechanical propellers** have been actuated by a special mechanism that is driven by a muscle force of a pilot or by an energy of a rotating shaft.

These propellers have limited application range, as they need pilot's supervision.

4. **On action**, hydraulic propellers are divided into propellers of direct, back and double action.

The **direct action propeller** is the propeller, which blades are turned to the lower blade angle side by the moments of oil pressure and transversal components of centrifugal force, and to the higher blade angle side – by the moments of transversal components of centrifugal forces of counterweights and aerodynamic force (Fig. 2.2, a).

The **back action propeller** is the propeller, which blades are turned to the lower angle side by the moments of transversal components of centrifugal force, and to the higher blade angle side – by the moments of oil pressure and aerodynamic force (Fig. 2.2, b).

The **double-action propeller** is the propeller, which blades are turned to both sides by the moments of oil pressure and transversal components of centrifugal force (Fig. 2.2, c).

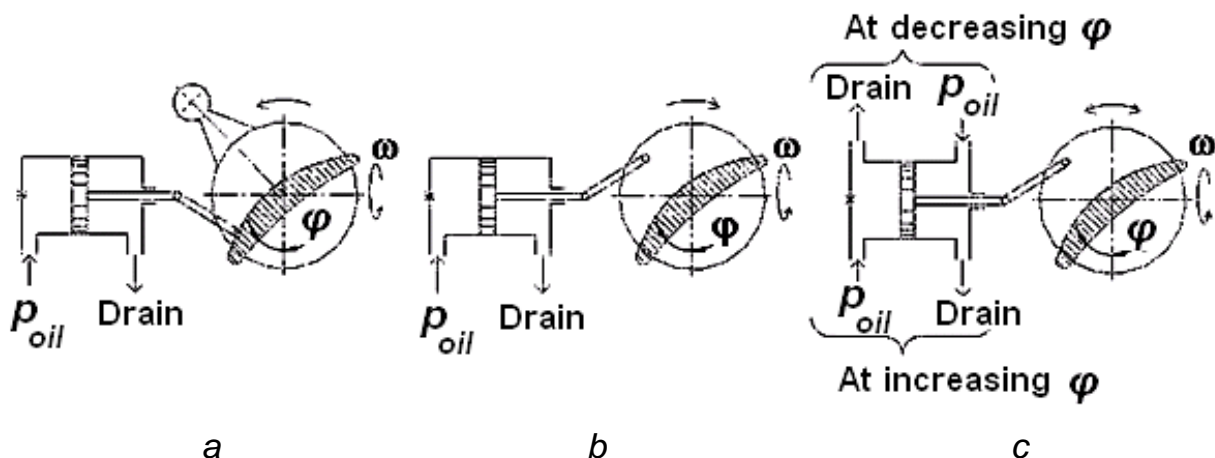

Fig. 2.2. Schemes of hydraulic propellers:
a – direct action (φ decreases); b – back action (φ increases);
c – double action

At malfunction of the oil system (for example at oil pressure dip), the back and double action propellers tend to lightening and spinning up of a rotor. The direct action propellers do not have this disadvantage, but they need counterweights that increase their mass.

The double action propellers have greater turning rate. However, they need a servomotor of double action that has a more complex construction, manufacturing process and maintenance.

5. On velocity w_1 (Fig. 2.3), propellers can be subsonic, transonic and supersonic.

The **subsonic propellers** are the most widespread. Their velocity w_1 is subsonic, hence $M_{w_1} < 1$.

Transonic propellers are the propellers where the essential part of a blade operates at $M_{w_1} \approx 1$. They have thin blades, which maximum width is displaced downstream.

The **supersonic propellers** are designed for $M_{w_1} = 1.8...2.0$. At these velocities, the wave drag coefficient is less than at $M_{w_1} \approx 1$. These propellers have high rotational speed (up to 5000 rpm), high specific diameter of the hub $D_{hub} = (0.35...0.45)D$, low airfoil thickness and low relative chord (at blade root $\bar{b} = b/l = 0.1$) and the greater number of blades ($i = 8 - 12$).

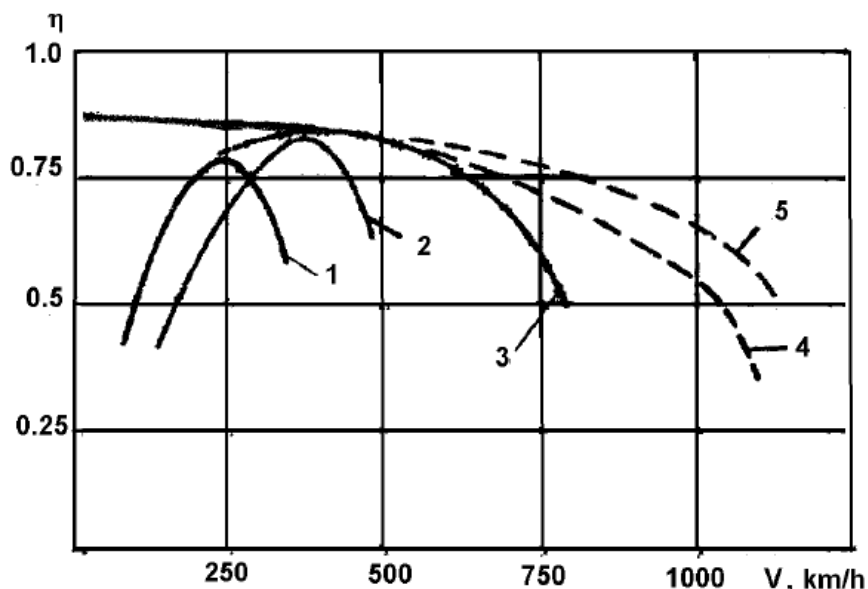

Fig. 2.3. Velocity vs efficiency relation of aircraft propellers:

- 1 – FPP with blades of traditional shape; 2 – FPP with blades of rectangular shape;
- 3 – VPP with blades of traditional shape; 4 – VPP with blades of scimitar shape;
- 5 – coaxial propeller with blades of scimitar shape

6. **On number of blades**, propellers can be two-blade, three-blade, four-blade and multi-blade. When the number of blades is small enough, they make no mutual influence and can be considered as an independent. For propellers with the greater number of blades, blades with bigger blade chords operating at greater velocity w_1 , the stated above is violated. So the blade mutual effect becomes a cornerstone for the propeller performance obtaining. The multi-blade propeller operation becomes similar to impeller of the fan of a high bypass ratio turbofan engine. These aircraft propellers are named as **propfans**.

7. **On blade shape**, propellers can have the direct and scimitar blades. The **scimitar shape blade** allows increasing flight velocity v_f at which the shock stall happens and the efficiency of propeller slumps.

8. **On number of blades rows**, propellers can be conventional and two-row coaxial.

The **coaxial propellers** include two contra-rotating coaxial propellers. Their advantages are:

- high efficiency due to straight exhaust (i.e. rear propeller straightens the flow twisted by the front propeller);
- zero reactive and gyroscopic moments (better aerodynamic performances and maneuverability of an airplane);
- smaller diameter (i.e. improved aerodynamic performances of an airplane and smaller distance between the fuselage and the landing gear).

Efficiency of different propellers depends on flight velocity (see Fig. 2.3).

Examples of coaxial propellers are AV-60K (NK-12 turboprop, Antonov An-22 and Tupolev Tu-95), and SV-27 (D-27 propfan, Antonov An-70).

9. **On braking capacity**, propellers can be conventional and **reversible**.

The reversible propeller must generate negative thrust at the reversal mode. As it has already been shown before, the negative thrust originates at some operating modes (wind turbine and braking modes). Conventional propellers use these modes for reversing.

Blades of reversible propellers are moved to the position with the negative blade angle φ_{rev} . Depending on how does the blade travel to the reverse position, the propellers are classified into that, which do this via the feathering position (Fig. 2.4, a), and that which do this via the zero blade angle position (Fig. 2.4, b). The latest

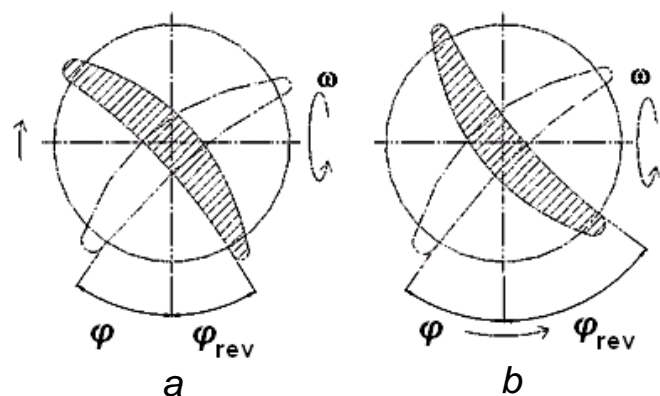

Fig. 2.4. Methods of blades driving to reverse position:

- a – through feathering position;
- b – through position of zero blade angle

needs less power to be actuated and can reach maximum reverse thrust mode with greater speed, providing the shorter landing run. However, the essential disadvantage of these propellers is poor control performance (keeping rotational speed within the specified range), when blades travel through the small blade angles area. Examples of the reversible propellers are the single-row AV-140 (Antonov An-140) and coaxial SV-27 (Antonov An-70).

10. **On feathering capacity** (the position with the minimum aerodynamic drag) in case of engine in-flight shutdown, there are specified the **feathering propellers**.

3. NEGATIVE THRUST AND PROTECTIVE MEASURES

3.1. Conditions of negative thrust in-flight origination

The thrust turns negative when the attack angle is negative (see Fig. 1.7). The blade angle in this case is positive. The negative thrust is typical for automatic variable pitch propellers. It may appear in the following conditions:

- engine failure and in-flight shutdown;
- blades are in the low blade angles region;
- pitch control failed (for example when oil pressure dropped);
- blades position overshooting at transient operating modes;
- blades are iced over (i.e. engine power is not sufficient to keep the rotational speed, and a speed governor turns the blades to the less pitch position).

All these conditions are reasoned by a speed governor, which tries to prevent rotational speed drop by decreasing the blade angle. Fig. 3.1 stores the dependence of turboprop thrust on fuel flow rate and flight velocity at $n = \text{const}$.

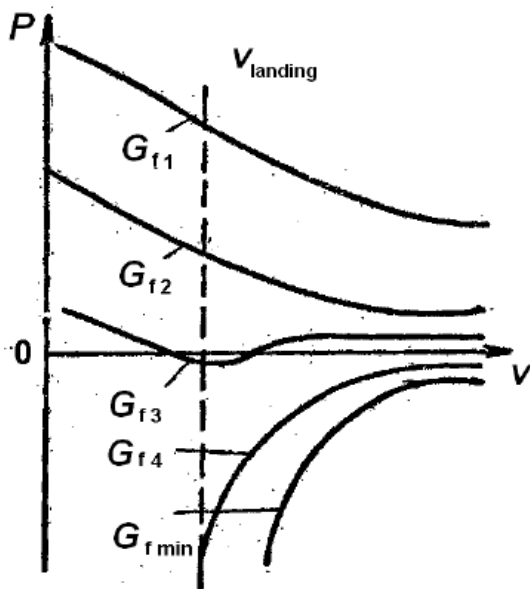

Fig. 3.1. Dependence of turboprop engine thrust on fuel flow and flight velocity

dependence of turboprop thrust on fuel flow rate and flight velocity at $n = \text{const}$.

At high fuel flow rates (G_{f1} and G_{f2}), the propeller operates in propelling mode. When the flight velocity increases, the blades turn to the greater blade angles. However, the attack angle goes down, making the thrust to fall. If the flight speed continues its growth, the propeller mode switches to zero thrust mode.

At low fuel flow rates and low flight velocity, the engine power is not enough to overcome a propeller drag. The propeller operates in wind turbine mode and goes out of governor control. Very high negative thrust originates. If the velocity continues to increase, the propeller operates in the breaking mode,

and the system «propeller-engine» windmills. The more the flight velocity is, the greater the blade angle is and the lesser the negative thrust is.

Thus, the **maximum negative thrust originates at low flight velocity and at the engine in-flight shutdown.**

The magnitude of the negative thrust depends on flight velocity, altitude and ambient temperature. When the altitude increases, the air density decreases, thus decreasing the negative thrust. When ambient temperature decreases, a consumed power increases. But the engine power is constant at $G_f = \text{const}$. So the speed governor switches the blades to the lower blade angles, thus initiating the negative thrust. The negative thrust grows at low temperature.

The negative thrust may simultaneously appear in all engines of an aircraft (for example during pre-landing gliding). It essentially complicates piloting and may cause flight incidents.

One more case, when the considerable negative thrust is possible, is when one engine of two fails. The negative thrust then may even exceed the maximum positive thrust. In these conditions, high turning moment acts on the aircraft. It yaws the aircraft to the fault engine side.

Therefore, the **prevention of negative thrust of turboprop engine belongs to important and urgent problems.**

All variable pitch propellers (VPP) are equipped with the **fine pitch stop** that limits the minimum blade angle φ_{\min} . This position is characteristic for stopped state and starting. The reversible propellers use this position at reversing during the landing run. However, the blades positioning at $\varphi = \varphi_{\min}$ does not preserve from the high negative thrust in the above-considered conditions.

3.2. Protective measures

The following safeguarding devices are implemented in the engines and propellers to limit the negative thrust and prevent the rotor overspeed:

- pitch (blade angle) stops;
- intermediate rests of blades;
- autofeather.

Depending on flight conditions, the engine operating mode and the cause of the propeller or its governor failure, one or some of above-mentioned devices will operate.

3.2.1. Pitch stops

Hydraulic pitch stop (HPS) blocks a draining cavity of a hydraulic cylinder that actuates propeller blades when the blade angle decreases to the minimum tolerant value (Fig. 3.2). The main element of HPS is valve 1 driven by piston 2 that is in the cylinder. When the oil pressure p_{oil} drops, the spring-

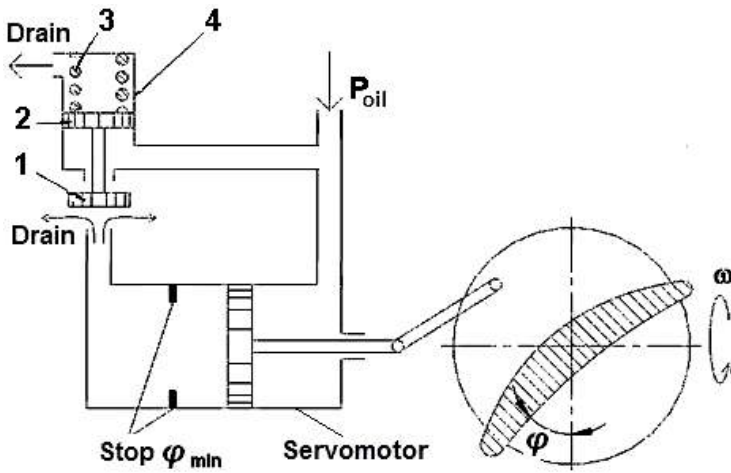

Fig. 3.2. Hydraulic pitch stop:
 1 – valve; 2 – piston; 3 – spring;
 4 – cylinder of hydraulic pitch stop

actuated valve terminates the oil drainage from the left-from-piston cavity. The cavity is blocked, and the propeller blades are stopped.

Mechanical pitch stop (MPS) mechanically stops the piston of a blade driving mechanism. This happens when the blade angle decreases because of action of the centrifugal moment of the propeller blades if there is no oil pressure in the control system (Fig. 3.3). When the piston moves, drive screw 1, which is

placed on a left rod, rotates the nut that supports the bearing. The cavity, which is on the left from nut 2, separates it from piston 7 that is splined 5 to a casing of hydraulic cylinder 9. Position of piston 7 is determined by the equilibrium of constant drain pressure force p_{drain} , pressure force p_{oil} in the left cavity of servomotor, and the force of spring 8 tightening. When the driving mechanism works in a normal mode, the pressure in the cavity between the nut and the piston overcomes the force of the spring and presses the piston to the spring, providing the nut turning and the blade angle alternation. When the oil pressure p_{oil} drops, piston 7 crawls to the right being acted by the spring. The splines on the piston's face intermesh with face splines of the nut. Thus, the nut gets mechanically (through splines 4 and 6, piston and splines 5) linked with the casing of the stop. It cannot turn anymore and cannot make the blade move.

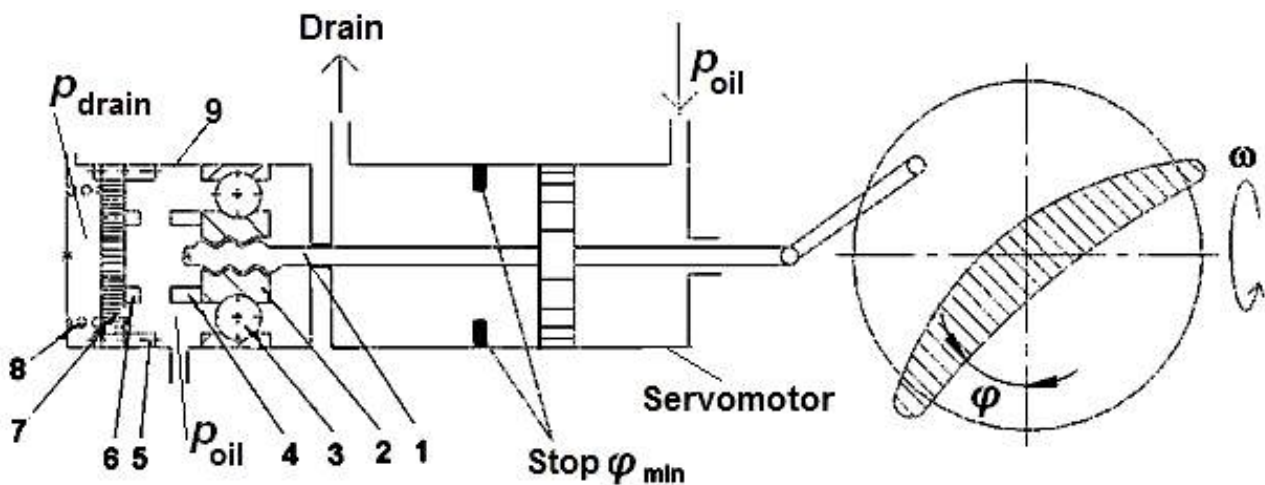

Fig. 3.3. Mechanical pitch stop:
 1 – drive screw; 2 – nut; 3 – bearing; 4, 6 – face splines;
 5 – splines on the cylindrical surface; 7 – piston; 8 – spring; 9 – cylinder of MPS

Centrifugal pitch stop (CPS), opposite to HPS and MPS, is immune to the blade angle or the oil pressure drop. It works according to the sensed rotational speed. Usually, it is used jointly with HPS as an additional device. The CPS operation is shown in Fig. 3.4. All elements are placed in the propeller hub and rotate. The CPS consists of a valve 1, which is joined to a weight 2, and spring 3 that supports the weight to the casing of the propeller hub. The weight supervises the drainage from the left (working) cavity of the servomotor. The spring stiffness, the weight position and its mass are selected to ensure $n \leq n_{max}$. The spring stiffness exceeds the centrifugal force of weight making the valve close the control line. The servomotor of the blades is at conventional operating mode. When the rotational speed breaks the maximum value ($n > n_{max}$), the centrifugal force of weight overcomes the spring stiffness. The valve close the control line and the oil pressure in the working cavity decreases. The hydraulic pitch stop is actuated (the valve of HPS blocks the left cavity of the servomotor).

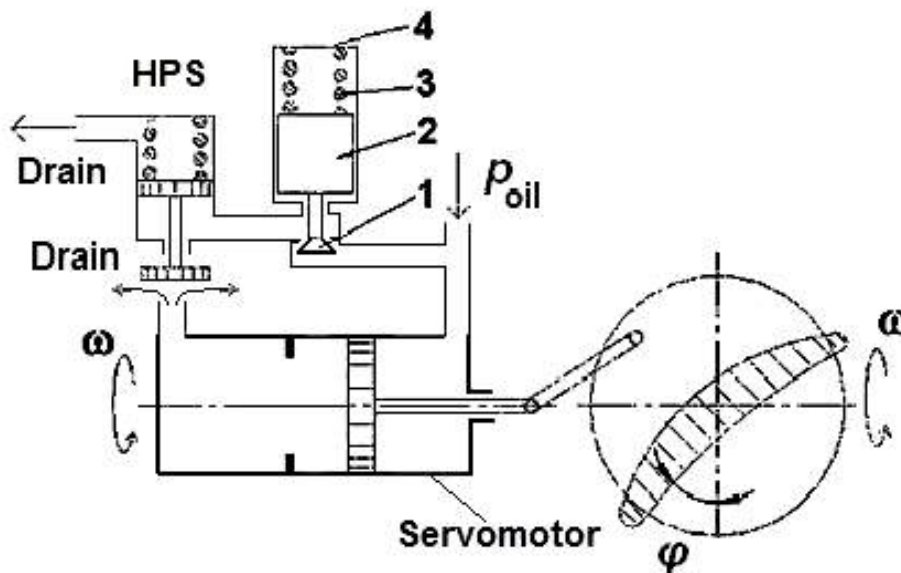

Fig. 3.4. Centrifugal pitch stop:

1 – valve; 2 – weight; 3 – spring; 4 – casing of propeller hub

3.2.2. Intermediate stop

The above-considered pitch stops snap into action in two cases: when propeller driving hydraulic system fails (HPS, MPS) or when the propeller overspeeds (CPS). However, even if the hydraulic system and the engine operate at normal mode, the high negative thrust may appear at the low operating modes (see Fig. 3.1) (descending and landing). Besides, at missed approach, if the blades take $\varphi = \varphi_{min}$ position, the acceleration time will increase, thus decreasing safety of flight.

To solve the enumerated problems, the propeller is additionally fitted with the intermediate stops. They fix the blades in the preset angular position φ_{IS} ($\varphi_{IS} > \varphi_{min}$). For example, the propeller AV-60 (NK-12 turbofan) has its intermediate stop at $\varphi_{IS} = 26^\circ$ (front propeller) and $\varphi_{IS} = 25^\circ$ (rear propeller), propeller AV-68I (AI-20 turboprop) – $\varphi_{IS} = 12^\circ$, propeller AV-140 (TV3-117VMA-SBM1 turboshaft) – $9^\circ 24'$.

Operation of the intermediate stop is shown in Fig. 3.5.

The working cavity A has the drain line that is opened by the hydraulic pitch stop. The intermediate stop consists of control line 1, valve 2, spring 3, spring stop 4, lever 5 and push bar 6 that is rigidly bounded to the piston rod of the servomotor. At high blade angles, the valve experiences the spring force pressing it to its seat. The control line is closed. When φ decreases, the piston 8 moves to the left. As φ becomes equal to φ_{IS} , the clearance between the push bar and the lever eliminates. The push bar actuates the valve 2 through a lever and opens the control line for draining. The pitch stop responds (HPS valve blocks the drainage from the left cavity of the servomotor) and propeller blades stay blocked in the position $\varphi = \varphi_{IS}$. At this position, the propeller gives low positive thrust, thus assisting in the successful landing of the aircraft.

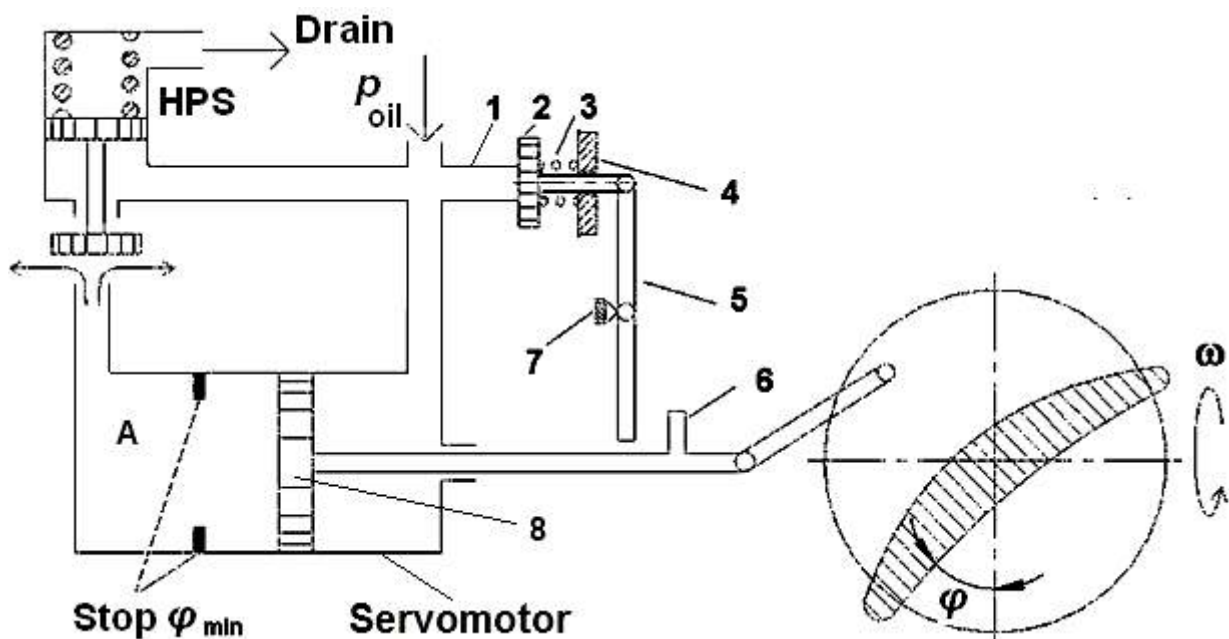

Fig. 3.5. Intermediate stop:

- 1 – control line; 2 – valve; 3 – spring; 4 – spring stop;
- 5 – lever; 6 – push bar; 7 – lever pad; 8 – piston of servomotor

The blades reach the intermediate stop automatically when the engine and the propeller starts the operating mode. The unstopping is made manually. After landing, pilot unfixes the intermediate stop (for example moving the lever pad 7 in Fig. 3.5 to the left) by special changers. The valve 2 gets back to its seat, the valve of HPS switches to the open position and the piston of servomotor moves to the left driving the propeller to the stop φ_{\min} . When aircraft performs the landing run, the generated negative thrust assists in the run distance shortening.

At the engine in-flight shutdown, the intermediate stop decreases (comparing to a stop φ_{\min}) the negative thrust overshoot.

Some propellers use a sliding intermediate stop, which position φ_{IS} depends on a flight velocity. The intermediate stop position increases with flight velocity. Fig. 3.5 shows that φ_{IS} changes when the lever pad 7 moves horizontally.

3.2.3. Feathering

Feathering system automatically drives the propeller blades to the feathering position ($\varphi_f \approx 90^\circ$) as soon as it receives the pilot's command. The feathering aims minimization of the negative thrust of the failed engine or the negative thrust and the rotor overspeed in case of the oil leakage.

The blades are feathered when:

- torsion torque drops at takeoff (takeoff autofeathering);
- excess negative thrust (full-mode autofeathering);
- propeller overspeeds.

The forced feathering is employed to check the propeller control system or in case of some control element failure.

When negative thrust originates, the propeller shaft is shifted a little against its supports. This shifting is used for the negative thrust detection.

One of the most considerable requirements made to the feathering is the feathering rate. The slow feathering may cause a negative thrust overshoot. As blade turn may play a key role in the reliability of the engine as a whole, so filling of a working cavity of a hydraulic cylinder at high rate goes to the top.

Therefore, a hydraulic system of the propeller includes the **feathering pump of high capacity** and an oil tank with a bay filled with the feathering oil. The feathering pump is powered by an electric motor because when the engine fails, it outputs zero power, and the rotor inertia may not be enough for driving blades to the feathering position. Additional emergency devices may be used in a feathering system. They drive the feathering pump in case the on-board electric system fails.

Unfeathering of blades on ground and in flight is made manually using the same system as it is used for feathering.

4. HUBS OF VARIABLE PITCH PROPELLERS

4.1. Blades turning by hubs of different schemes

Electromechanical and hydraulic variable pitch propellers (VPP) need a servomotor that drives blades using electric power or power of high-pressure liquid. The driving system is arranged inside a propeller hub.

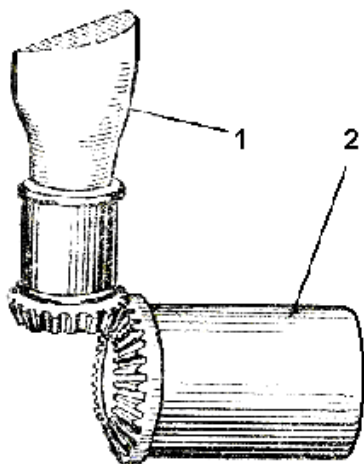

Fig. 4.1. Scheme of electromechanical VPP:

- 1 – propeller blade;
- 2 – electric motor

The centrifugal speed governor is a component of the electromechanical VPP. It acts on the electric motor that turns the blades via gears (Fig. 4.1).

The hydraulic VPP use oil for blade driving. Hydraulic VPP found its use in the most modern airplanes powered by the turboprops.

Conventional hydraulic VPP contains the pump that is built in the speed governor, and a piston servomotor that is built in the propeller hub.

The rectilinear motion of the piston is transformed into rotary motion of blades due to a rocker or a crank.

Servomotors can go into single-side or two-side action. The operation of the two-side action VPP is shown in Fig. 4.2. The oil pressure changes the pitch. The piston 4 travels in the cylinder 5. The piston is connected to the propeller blades through the connecting rods 1 and pins 7.

The oil enters the cylinder 5 through the slide valve. It is governed by a centrifugal speed governor. Cavity B is fed through the line 6 (Fig. 4.2, a) and cavity A is fed through the line 3 (Fig. 4.2, b). Entering the cavity B oil forces the piston to move to the right. It pulls the oil out of the cavity A to the oil tank. The blades are turned to the low pitch angle region.

Propellers of two-side action are used for high-power turboprops.

Engine of intermediate power use single-side VPP. Their blades are turned to one side by the oil pressure and to the other one – by the centrifugal force. These VPP may be of direct (Fig. 4.3) or back (Fig. 4.4) action.

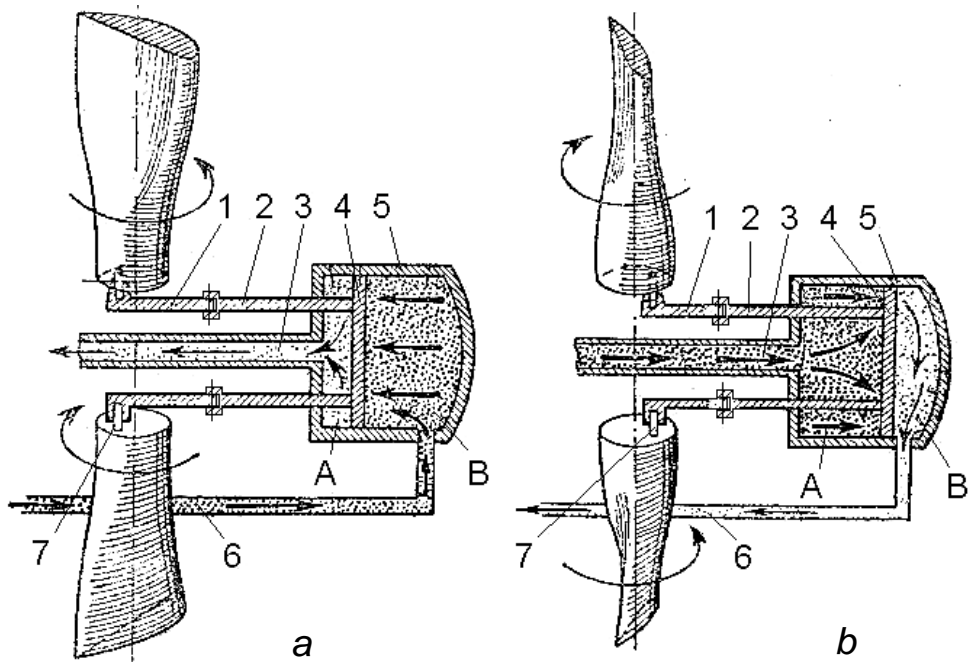

Fig. 4.2. Operating principle of hub of the double-action hydraulic VPP:
a – pitch increasing; *b* – pitch decreasing;
 1 – connecting rod; 2 – dog; 3 and 6 – channels; 4 – piston; 5 – cylinder; 7 – pin

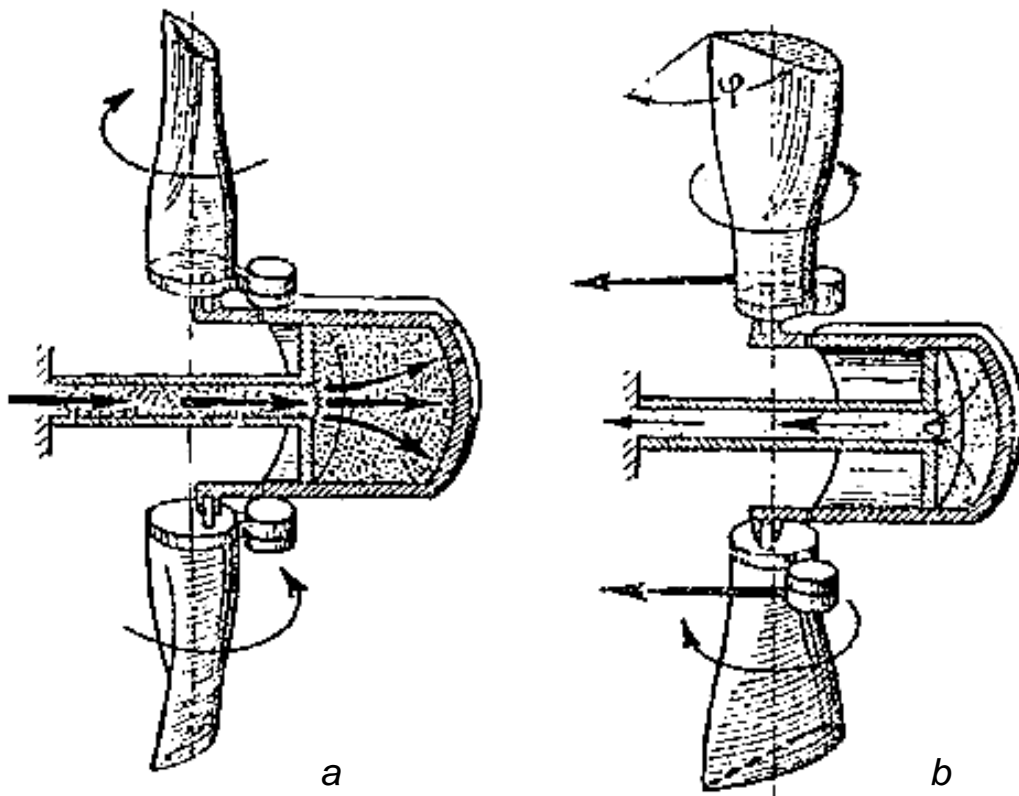

Fig. 4.3. Operation of hub of hydraulic VPP that operates on direct-action scheme:
a – pitch decreasing; *b* – pitch increasing

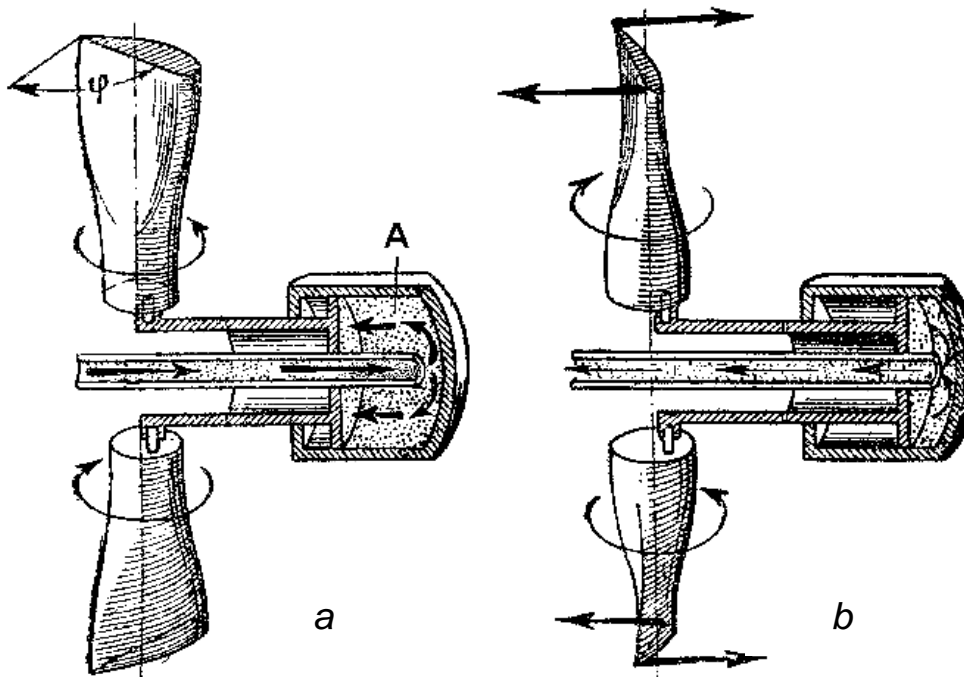

Fig. 4.4. Operating of hub of hydraulic VPP that operates on back-action scheme:

a – pitch increasing; b – pitch decreasing

The centrifugal force makes the conventional-shape propeller blade turn to lower pitch. Therefore, VPP of direct action is equipped with a counterweight (Fig. 4.3) that turns the blade to higher pitch. When the oil pump increases pressure (Fig. 4.3, a), the piston slides to the right decreasing the pitch. When the oil pressure decreases (Fig. 4.3, b), the centrifugal force of counterweights increases the blade pitch. The piston moves to the left, forcing the oil back to the tank.

The operation of the back-action VPP is shown in Fig. 4.4. The oil enters the cavity A and forces the piston to the right, thus turning the blades to greater pitch (Fig. 4.4, a). Centrifugal force turns the blades to lower pitch (Fig. 4.4, b). The piston moves to the left and forces the oil from the cavity A.

The gear pump supplies the oil into the VPP cylinder. The oil is taken from the engine lubrication system.

4.2. Construction of main elements of VPP hub

The hub bears blades and feeds them with torque from the engine shaft. The hub includes a turning mechanism and add-on devices that improve reliability and safety of the propeller (pitch stops, feathering mechanism and ice protection system).

Main elements of the VPP hub are casing and blades driving mechanism.

The **casing** 5 (Fig. 4.5) is the main load-bearing element. Due to its characteristic shape, this part is also named as **hub spider**. It is cylindrical box with cylindrical cuffs that are equispaced radially on its side surface. The number of cuffs is equal to the number of blades (2...4 for subsonic propellers).

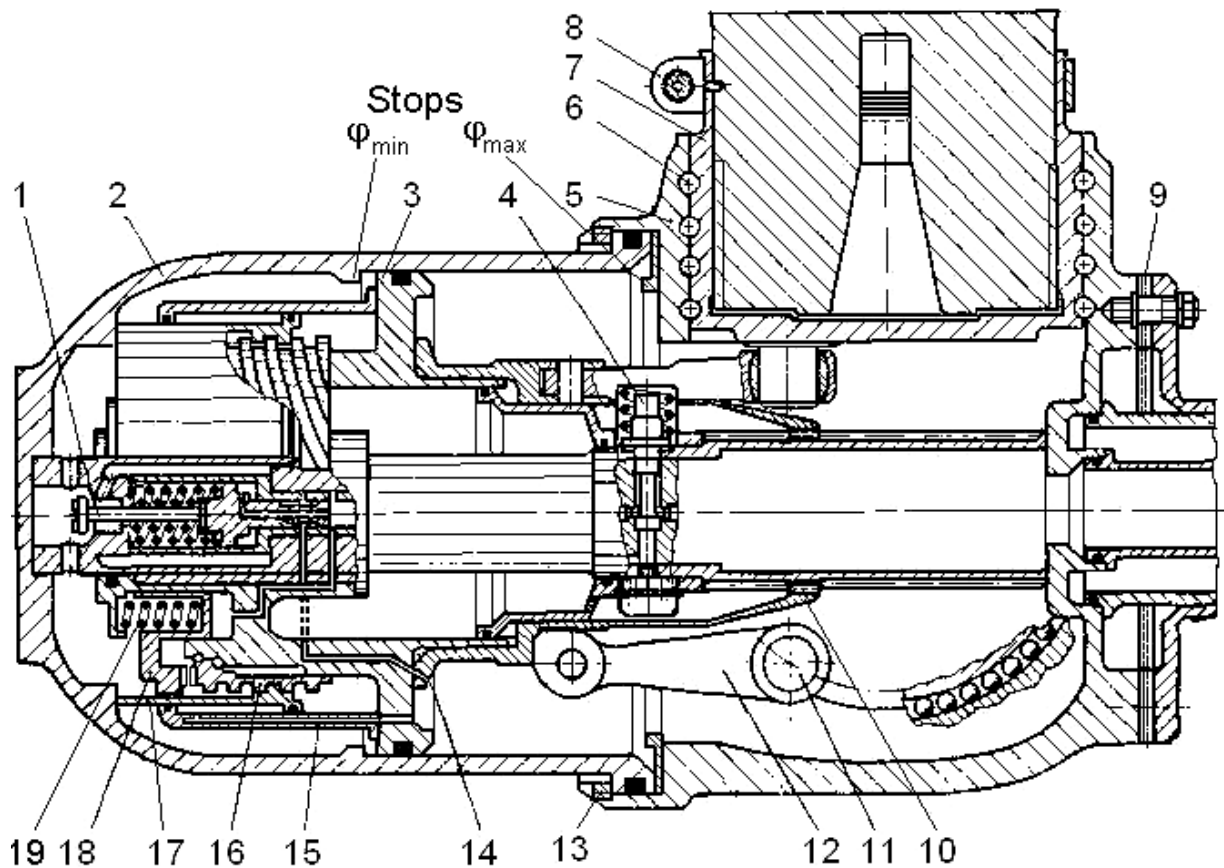

Fig. 4.5. Hydraulic hub of VPP:

- 1 – hydraulic pitch stop; 2 – cylinder; 3 – piston; 4 – centrifugal pitch stop;
 5 – casing (spider); 6 – blade retention ball bearing; 7 – blade cartridge; 8 – clamp;
 9 – shaft of gearbox; 10 – splined cross bar; 11 – pin; 12 – connecting rod;
 13 – nut; 14 – channel of intermediate stop; 15 – stop; 16 – rotating hub; 17 – sleeve;
 18 – piston of splined hub; 19 – spring

The hub casing is solid-forged without mount split in the plane of rotation for higher rigidity and lower mass.

The casing is loaded by centrifugal and aerodynamic forces of blade masses, by bending moments of centrifugal and aerodynamic forces (they act as in axial plane so in the plane of rotation), by bending moment of Coriolis forces of blades (originates during the airplane maneuvers). The centrifugal force of a single blade can reach 800...1000 kN, the total bending moment – 7...10 kN·m.

Flange-bolt joint between the hub and the propeller shaft is the most widespread. The propeller shaft ends with a flange with triangular splines on its end surface 9. The rear wall of the casing 5 has the flange with the splines too. The splines transmit the torque, and mutually center the shaft and the hub.

The hub is studded to the shaft. The studs are loaded with the thrust, force caused by inertial bending moment and axial force that initiates in a splined junction when the torsion torque is transmitted.

The blades are secured in the intermediate cartridge 7 by the blade retention bearing 6 (see Fig. 4.5). The blade is centered by surface 5 and support ring 9 (Fig. 4.6). The blade is screwed in the cartridge and clamped 2 in the top split piece of the cartridge. The balls are putted into blade retention bearing through mounting holes 7. The bearing races are cup-shaped. When nut 3 is tightened, the balls become shifted against the mounting holes, thus preventing their drop out.

The blade fixation assembly is loaded with the centrifugal force, thrust and circumferential force and also by moments of these forces.

The blade driving mechanism must synchronously turn the blades within the range of angles $0...90^\circ$ with turning rate being greater than $7...10^\circ/s$. It must be simple, compact and reliable. The hydraulic piston servomotor of two-side action fulfills these requirements.

The **servomotor** (see Fig. 4.5) consists of cylinder 2, piston 3 and crank mechanism that transforms the translational motion of the piston into the blades turning. The piston-cylinder sliding pair is sealed by a rubber gasket. Axial displacement of the piston is limited by the stops that correspond to maximum and minimum blade angle positions. The cylinder is attached to front wall of the hub casing by the nut 13. The axial force of the oil pressure acting on the cylinder wall reaches $(4...5) \cdot 10^5$ N. The crank mechanism consists of the pin 11 and the connecting rod 12. The pin is eccentric to the end of the blade cartridge. The connecting rod is joined by one end to the pin and by other end to the piston. This mechanism provides the required range of the blade turning angles.

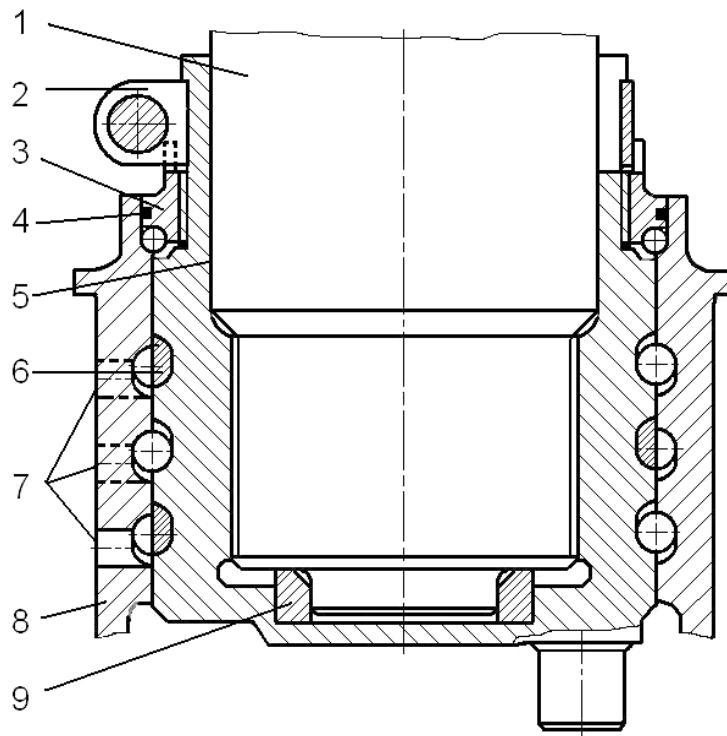

Fig. 4.6. Blade fixing to hub casing:

- 1 – blade root; 2 – clamp; 3 – nut; 4 – seal ring; 5 – centering surface;
6 – cage; 7 – mounting holes; 8 – hub casing; 9 – support ring

The pin 4 (Fig. 4.7) is placed in cross bar 3. It is constrained from drop out by fixing screw 2, whose cylindrical part enters the groove in the pin.

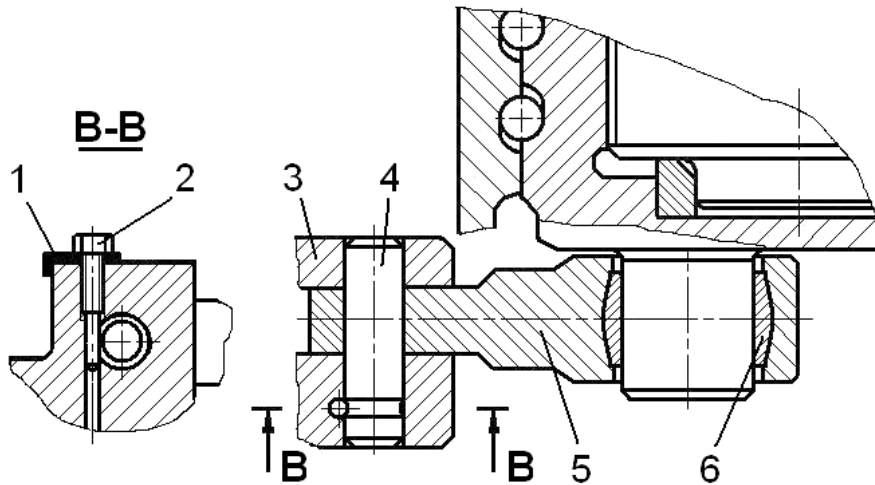

Fig. 4.7. Junction between connecting rod, cross bar and pin of cartridge:

- 1 – locking plate; 2 – fixing screw; 3 – cross bar;
4 – pin; 5 – connecting rod; 6 – spherical sleeve

The driving force P_d is decomposed into coaxial to connecting rod force K (Fig. 4.8), and side force N :

$$K = P_d / \cos\beta; \quad N = P_d \tan\beta,$$

where β is the angle between axis of the connecting rod and the piston.

Force N acts on arm B and generates the moment that trends to turn the piston around its axis. The cross bar 10 (see Fig. 4.5) provides only rectilinear motion. From one end it is joined to the piston, from the other end, it is splined to the hub casing.

The force K is decomposed into the perpendicular to crank component T (tangential component), and the coaxial to axis component Z (normal component):

$$T = K \sin(\varphi + \beta) = P_d \sin(\varphi + \beta) / \cos\beta,$$

where φ is the blade angle that is related to angle β as

$$R \sin\varphi = a + L \sin\beta,$$

L is the length of connecting rod;

a – offset distance.

The product of the force T and the arm R generate the driving moment that can be evaluated as

$$M_d = TR = P_d R \sin(\varphi + \beta) / \cos\beta.$$

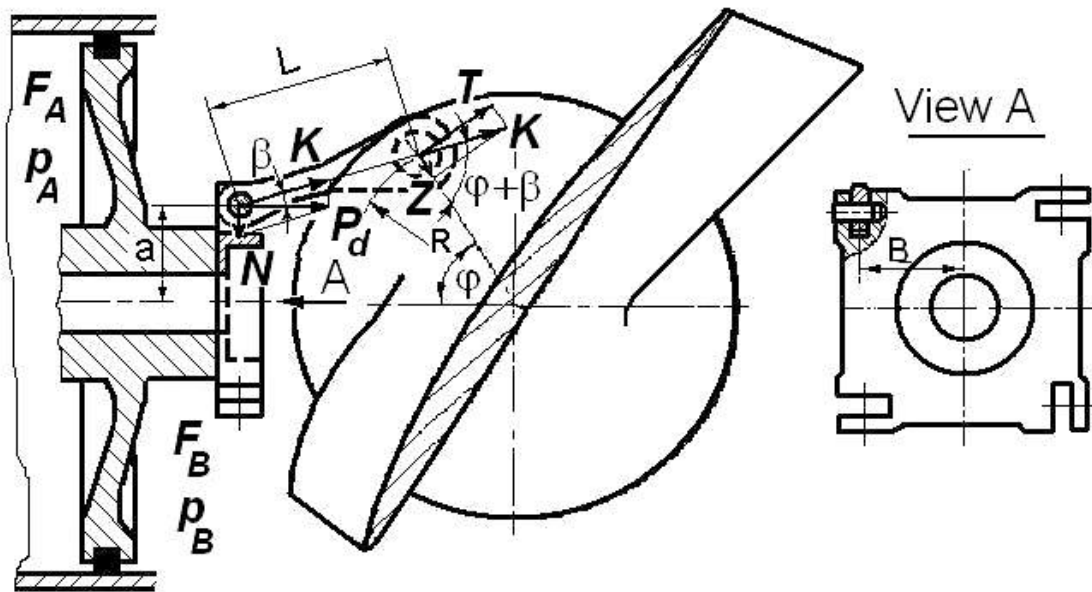

Fig. 4.8. Distribution of driving force on elements of crank-and-gear mechanism

The driving moment must be high enough to overcome the sum of moments generated by the transversal components of centrifugal and aerodynamic force, friction in the blade driving mechanism, and inertia of the blades and all other turning parts. The moment of transversal component of centrifugal force tends to decrease the pitch, and the moment of aerodynamic forces tends to increase the pitch. The available driving force of the piston

$$iP_d = F_A p_A - F_B p_B,$$

where i is the number of blades;

F_A, F_B, p_A, p_B are areas and oil pressures on the left and on the right from the piston respectively.

The oil pressure is chosen to provide the required blade turning rate. The pitch is decreased using the oil from the engine oil line (pressure is 600...800 kPa) and the moments of transversal components of centrifugal forces of blades. The oil pressure permanently acts on one of the piston sides. The blade pitch is increased by the oil at high pressure (2...4 MPa). It is supplied by an oil pump that is all in one with the speed governor. To increase the pitch, the driving moment must overcome the moment of transversal components of centrifugal forces of blades, that sometimes may reach 30...50 kN.

4.3. Add-on devices of VPP hub

The add-on devices of VPP hub include pitch stops, intermediate stops and ice-protection system.

The pitch stops fix propeller pitch automatically at a speed governor failure or at propeller hydraulic control system malfunction, thus preventing the propeller overspeed. VPP hubs have hydraulic, mechanical and centrifugal pitch stops.

4.3.1. Hydraulic pitch stop

The hydraulic pitch stop (HPS) 1 (see Fig. 3.2) fixes the blade positions by shutting down the oil flow from the left cavity of the rim when the oil pressure drops.

The HPS has a mitre valve 1 (Fig. 4.9). When the propeller operates normally, the valve is kept open by pressure of oil that is supplied to the right cavity from the piston 6.

When the oil pressure drops, the spring 4 forces the valve to the right until it will block the oil outflow from the cavity of the cylinder. The residual oil in this cavity serves the hydraulic stop. Thus, the propeller pitch decreasing and overspeed are prevented.

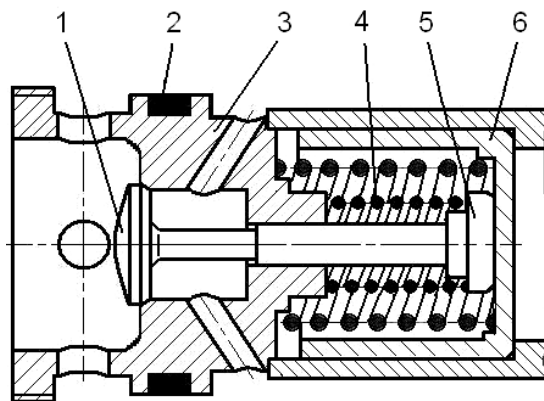

Fig. 4.9. Hydraulic pitch stop:

- 1 – mitre valve; 2 – seal; 3 – casing of the stop;
- 4 – spring; 5 – back-up plate; 6 – piston of the stop

4.3.2. Mechanical pitch stop

The mechanical pitch stop (MPS) fixes the propeller pitch when there is no oil in the system. This might happen if the cylinder-piston seal fails. It also prevents the «right-slipping» of the piston in the hydraulic stop position when the oil leaks from the cylinder.

An example of the mechanical pitch stop is shown in Fig. 4.10. The stop element is sleeve 3 that is pushed to the cylinder of the VPP driving mechanism by the oil pressure, which acts on its face.

The sleeve is joined with the turning hub 5 by screw splines. The turning hub is joined to the piston 7 by the ball bearing 6. When the VPP operates at normal mode, the sleeve allows free motion of the piston to the right due to the

turning of the turning hub 5. The turning hub is controlled by the spline clutch 4. The clutch has radial and face splines and a piston. The clutch is permanently splined to the jimmer of the sleeve 3. The face splines confront to jimmer face splines of the turning hub 5. When the oil pressure drops, the springs 2 displace the splined clutch 4 to the right until it intermeshes with the face splines of the turning hub 5. The latest are fixed and cannot turn, thus axially fixing the piston of the VPP driving mechanism. So, the sleeve 3 plays a role of the mechanical stop.

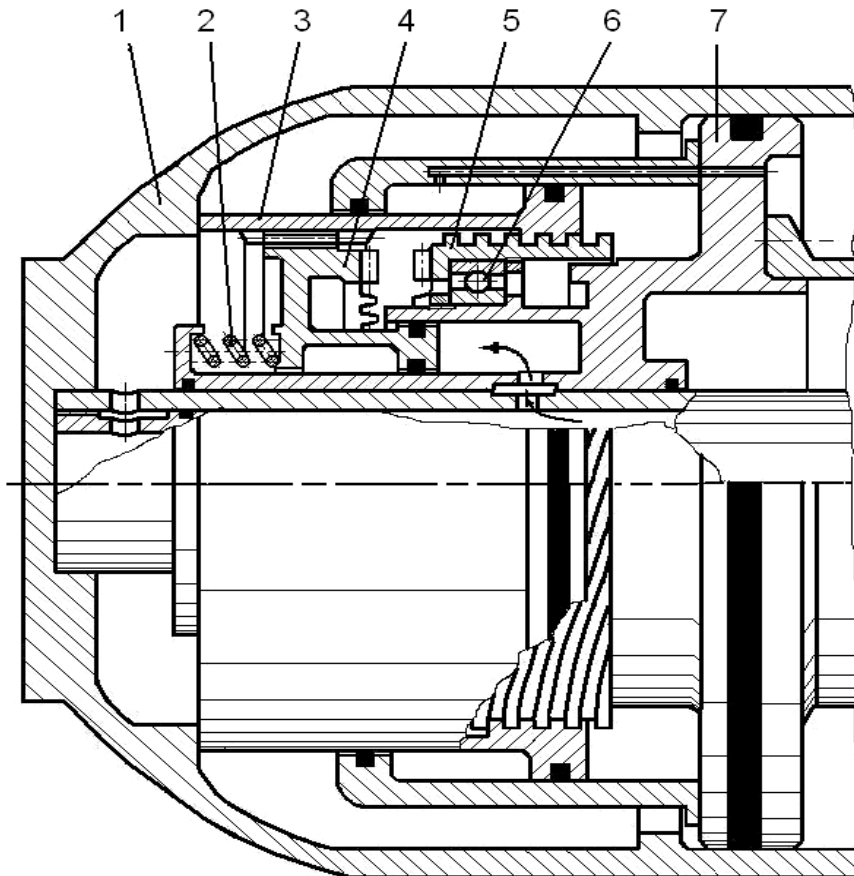

Fig. 4.10. Mechanical pitch stop:

1 – cylinder; 2 – spring; 3 – sleeve; 4 – splined clutch;
5 – turning hub; 6 – ball bearing; 7 – piston

4.3.3. Centrifugal pitch stop

The centrifugal pitch stop (CPS) prevents the propeller from overspeed when the speed governor fails. When the rotational speed gains the maximum, the pilot valve 1 (Fig. 4.11) moves radially because of the centrifugal force generated by its own mass and mass of weight 6. It overcomes the tension of the spring 5 and bleeds the oil from under the piston cavity of the hydraulic pitch stop. Hereupon, it actuates the HPS. Thus, the propeller pitch is fixed hydraulically and mechanically, and prevented from the overspeed.

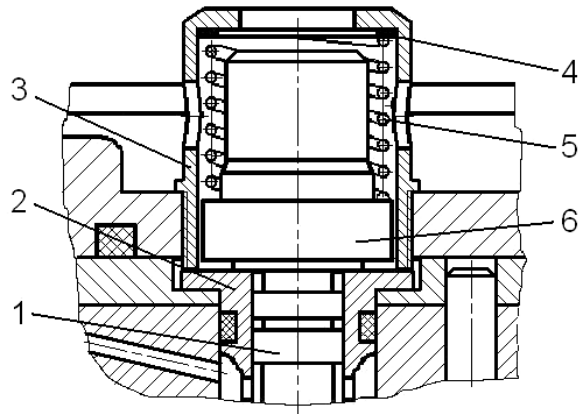

Fig. 4.11. Centrifugal pitch stop:

1 – pilot valve; 2 – hub; 3 – cap; 4 – adjusting washer; 5 – spring; 6 – weight

When the rotational speed decreases, the centrifugal force of pilot valve mass decreases and the tension brings the pilot valve back to its initial position. The piston of propeller driving mechanism leaves the hydraulic stop.

4.3.4. Intermediate stop

The *intermediate stop* prevents from reaching the mechanical pitch stop, thus preventing high negative thrust.

The intermediate stop position corresponds to the blade angle $\varphi_{IS} = 25...26^\circ$. When the blade angle decreases, the channel 14 (see Fig. 4.5) in the piston becomes interconnected with the channel in the HPS. The oil is drained from the right cavity of the HPS, thus closing the valve and actuating the hydraulic stop. When the pitch increases, the blades are not fixed by the intermediate pitch stop because the valve of HPS is outpressed by the oil pressure.

4.3.5. Ice protection system

Blades and cowl of propeller must be protected from ice. Liquid or electrical ice protection systems can be used.

Liquid systems: A water–spirit mix (for example isopropyl alcohol) sprinkles everywhere along leading edge of the blade. The deicing fluid is stored onboard in the reservoir in sufficient quantities for normal demand. The fluid is fed to the propeller by an electrically driven anti-icing pump. The propeller is equipped with a slinger ring having nozzles aligned with the leading edge of each blade. Experiencing the centrifugal force, the fluid exhausts from the nozzles and propagates along the leading edges of the propeller blades. This prevents ice from accumulating on the blade faces. The length of time the system can protect the blades from icing depends on the fluid store and the spray rate. This system is high-weight comparing to electrical systems. So it found no use in modern aircraft.

Electric system is widespread. The system consists of heating elements, AC generator and control elements. The heating elements (Fig. 4.12) are made of the electroconductive rubber 3. They are pasted on leading edges of blades and a fore part of the cowl. The heating element contains the electric conducting buses 5 made of brass gauze and pressed to longitudinal border of the element. The ends of conducting buses go out at the blade root. They are joined to terminals of electric generator. Current flows from one conducting bus to another, and heats blade surfaces where the ice adheres. The combination of heat, centrifugal force and the blasting airstream blow the accumulated ice. The ice blanket volume and its mass must reach the definite magnitude prior to be torn out by the centrifugal force. The frictioned fabric 4 insulates the electroconductive rubber 3 from the blade. The electroconductive rubber is covered by the non-electroconductive rubber 2 to prevent its wear out. The heating elements are powered from time to time (not continuously). That conserves the electric power while still providing effective deicing. During the time between the operational time slices, the ice is accumulated on the surfaces. The electric power arrives by wires through brushes and contact rings of current collector.

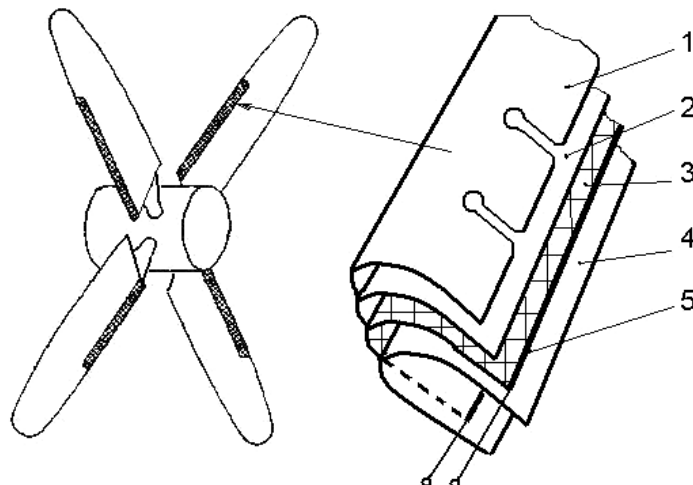

Fig. 4.12. Heating element:

- 1 – protective metal strip; 2 – non-electroconductive rubber;
- 3 – electroconductive rubber; 4 – frictioned fabric; 5 – conducting buses

5. AIRCRAFT PROPELLER AV-60

5.1. General

NK-12 turbofan is fitted with the coaxial aircraft propeller AV-60 (Fig. 5.1). The propeller converts rotary motion from an engine into thrust for flight or into negative thrust – for speeding down the aircraft during landing run. The propeller consists of two four-blade contra-rotating VPP: the front right-handed propeller and the rear left-handed propeller (looking along the flight direction).

The governor R60 and control devices maintain constant rotational speed within entire operating range. They automatically change the blade angle.

The hydraulic pitch control is back-action. Pitch is increased by oil supplied by a speed governor to the cavities A. The pitch is decreased as by the moments of transversal components of centrifugal forces so by the oil that gets into the cavities B from the oil line of the engine. At the same time, pistons force the oil out from the cavities A to inside of the engine casing.

In emergency conditions when the oil pressure drops, the hydraulic pitch stops fix the propellers.

If the rotational speed exceeds 820^{+15} rpm, then the centrifugal pitch stop (CPS) will fix the pitch automatically via the hydraulic pitch stop (HPS).

The intermediate stops fix the blade at some positions between the maximum and minimum pitch, thus preventing high negative thrust. This is very urgent when the aircraft descends until the touchdown and the engine operating mode decreases. When the airplane makes the go-around then the engine sharply increases the operating mode. The blades being fixed at intermediate angle let the fast propeller loading and, hence, takeoff thrust gaining.

The switching from the intermediate stop to taking off, reversing, dereversing and defeathering positions is made forcibly. The feathering is automatic and forcible.

Feathering oil pump 451A serves to feather the propeller. The 451A consists of the oil pump itself and the electric engine D-3000M.

The oil pump feathers and defeathers blades. It consists of two pairs of gears. Each pair forms an individual pump with its own discharge pipe for independent oil supplying to each propeller row. Both pairs of gears have common drive from the electric motor. The oil pump has two pressure-reduction valves and one check valve.

The check valve ensures the oil circulation in the feathering system when the governor operates at normal mode. If the governor fails, the check valve blocks the circulation holes to let the feathering pump operation. The pressure-reduction valves maintain the constant pressure equal to 6^{+1} MPa.

Each pump capacity is 30 l/min.

Characteristics of propeller AV-60

Type-tractor coaxial propeller of variable pitch with feathering and intermediate stop	
Number of blades	4+4
Diameter	5.6 m
Hand of rotation (flight looking forward):	
– front propeller	right
– rear propeller	left
Rotational speed (takeoff)	
– propeller	790 rpm
– engine	9000 rpm
Blades turning mechanism	hydro-centrifugal
Blade angle at control section $R = 1.6$ m:	
• angle of minimum rotational drag (starting angle) φ_0 :	
– front propeller	7°
– rear propeller	5°
• intermediate stop angle φ_{is} :	
– front propeller	26°
– rear propeller	25°
• feathering angle φ_f :	
– front propeller	91°
– rear propeller	92°
Mass	1190 kg
Time interval of in-flight feathering (max time)	10 s

5.2. Construction

The propeller AV-60 consists of the following assemblies and parts:

- front propeller hub;
- rear propeller hub;
- blades;
- ice-protection system.

5.2.1. Front propeller hub

The casing of the front propeller hub (Fig. 5.1) consists of casing 1, four cartridges 25, their nuts 21 and four lock washers 24, four clamps 22, textolite rings 29 and rubber oil seal rings 30. The casing joins all parts together and the engine shaft.

The casing of the hub is made of steel alloy. The seats, also known as cantilever arms carry the blades. The seats contain the cartridges that rest in a four-row blade retention bearing 26. Each row contains fifty-two balls.

Profiles of fillets in the cantilever arm are single-radius, and the profiles of fillets in the cartridge 25 are two-radiused: the first one is the working one and second is for balls mounting. The balls are inserted through four holes in the casing. The holes are shifted against the fillet's center to the axis of the casing.

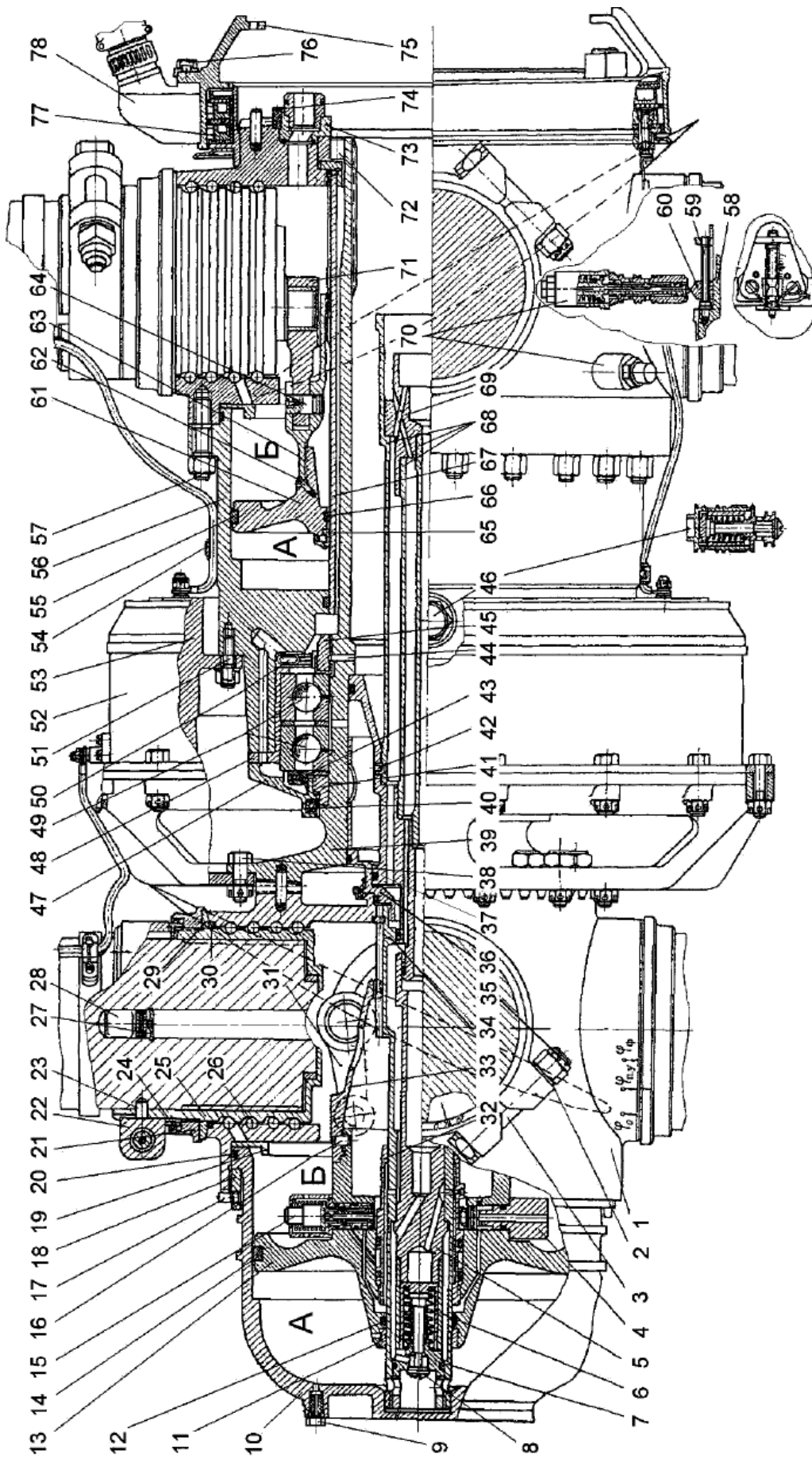

Fig. 5.1. Hub of aircraft propeller AV-60

Leak-proofness of cartridges is provided by the rubber oil seal ring 30.

The nut of cartridge 21 provides axial tightness of the cartridge in the cantilever arm. The textolite ring 29 lessens the friction between the nut and the face of cantilever arm.

Having been tightened, the nut is secured by the fixing spacer 24, three teeth of which enter grooves in cartridge, and the external splines of which are joined to the nut's splines. The clamp 22 prevents the fixing spacer drop out. The casing is joined to the engine shaft by face splines and sixteen forcing studs that are threaded into the casing by drive fit.

The front part of casing has the flange with internal thread for fixing cylinder 10 by nut 17. The external surface of the casing has four eyes welded between the cantilever arms. The eyes bear the bolts that fix the cuffs. The cartridge 25 is made of steel alloy. The inner surface of the cartridge is threaded for blade screwing. The thread of front-propeller cartridges is right-hand and of the thread of rear-propeller cartridges is the left-hand.

The blade is centered by two centering fillets on inner surface of the cartridge. Three cuts in the top of the cartridge provide reliable pressing of the blade root in the cartridge, thus preventing its turn and assisting the clamp in blade tightening. The tightening torque of the clamp is 400...450 Nm. The scale is marked on the end of cartridge. It serves to place the blade in the initial blade angular position. The scale consists of twenty graduations of 1° each.

The cartridge also has a made all in one pin in its bottom. The connecting rod 31, connecting the cartridge with the piston, is joined to the pin.

The clamp 22 is the split steel collar. Bosses with holes for tightening the bolts 3 are made in area of split. The nut 3 is fitted under spacer 2. The spacer and the head of tightening bolt have spherical support surfaces, which prevent the bolt from being bended during clamp tightening. The nut is splinted 35.

The piston assembly of the front propeller consists of piston 13, cross-bar 33 adjustment hub 32 and centrifugal pitch stop 15. The piston is made of duralumin. The outer surface of piston has a groove with rubber seal 14 inside. The rear surface has two milled areas with end-to-end holes. One side of the rear surface secures the centrifugal pitch stop. The other one secures counterweight 4. The counterweight carries the jet for the oil circulation purposes. The oil intends to heat the propeller hub. The oil must circulate to avoid its overcooling inside the hub. The centrifugal stop 15 consists of pilot valve, sleeve of pilot valve, spring and cup.

Inner surface of the piston 13 is threaded to adjustment hub 32. The inner surface also has two fillets for centering the bronze sleeve 11 and for the rubber seal ring 12 fitting.

The steel adjustment hub 32 is used for the hydraulic stop adjustment. Screwing the hub into the piston changes setup of the intermediate stop (the blade angle grows bigger). After adjustment, the hub is fixed by the weight 4, the tail of which enters the cut in the hub. Surface of the hub 32 contains two

cuts for centering. The cuts are mutually distant at 180°. The piston 13 is threaded to the cross-bar 33 and locked by pin 19. The cross-bar is made of steel. Its external surface has a flange with four eyes for attaching the connecting rods 31. The connecting rods are pinned 64 to the cross-bar. The pins 64 are fixed by screws, and the screws in their turn are fixed by the fixing wire.

The oil line of the front propeller is the steel pipe 34. Hydraulic pitch stop (HPS) and duralumin insertion 5 are mounted inside this pipe. On one side, the pipeline is splined to the casing and is secured by nut 36. On the other side, the pipeline is centered in the groove of the cylinder. The piston is allowed only for rectilinear movement, because it is constrained from turning by the oil line splined to the cross-bar and the hub casing. Thus, pins are precisely oriented against the cartridge. The HPS consists of casing 7, valve 8, two springs, spacer and piston 6.

Cylinder of front propeller 10 is made of duralumin. It ends with a mounting flange with the groove for the rubber gasket 20. The outer surface of the cylinder has the groove for fitting the clamp that secures the wires of the ice protection system.

The tip of the cylinder has a flange for mounting a pipe. It centers the cowl. The pipe is fixed by eight studs. The cover 9 relieves the air from the cylinder while mounting the latest on the propeller casing. The ring boss inside the cylinder plays as a piston stop that corresponds to blade position during the starting phase. The feathering position is limited by two duralumin half-washers 19.

The cylinder and the half-washers are joined to the casing by the nut 18. The latest is fixed by the screw 17 that in its turn is wire-locked.

The shaft of front propeller 39 joins the front propeller with the engine shaft. On the one end, the shaft has the flange with face splines and holes for studs that join the shaft to the propeller hub. Besides, the flange is interconnected to the disc with bolts 38. The disc bears the outer part of generator 52 and four pairs of electric conductors. They connect the generator with the heating elements of the front propeller blades. On the other end, the shaft has splined inner surface that is in charge for joining shaft of gearbox. The shaft rests on three bearings in the rear propeller hub: two ball bearings 49 – in the cylinder of the rear propeller and one roller bearing 72 – in the casing of the rear propeller. The oil that lubricates and cools ball and roller bearings is supplied from the command line through jet 42. The oil is scavenged from cavities of roller bearings by scoop pump 45 that is a nut with two diametrically opposite pipes 50. When the shaft rotates, the scoop pump furnishes oil by the pipes and, due to high relative velocity of opposite rotation of propellers, directs the oil through the hole 44 to inside of the shaft and to the draining line in the engine gearbox.

The leak-proofness of the junction between the shaft and the crankcase is provided by oil seal cuff 40 mounted on cup 47, and by the oil thrower ring 41 and cuff 43 mounted on the shaft.

The oil receiver of front propeller consists of distributor 37 and receiver itself 69 made of duralumin and joined by three steel pipes 68 using pressing fit.

The distributor 37 contains threaded jet 42 for bearings lubrication.

5.2.2. Rear propeller hub

The cylinder 56 is a load-bearing part. It takes weight and thrust of front propeller through the shaft 39, double ball bearing, cap 47 and studs. The cylinder is made of duralumin. It is studded to the casing of the rear propeller hub by twenty-four studs 57.

The front face of cylinder contains sixteen studs that fix bearing cage 48 with cap 47.

The cylinder has oil-supplying channels. They deliver the oil inside the cylinder. The cylinder also has a socket for HPS mounting, the construction of which is same to the HPS of the front propeller. The projected part of the cylinder bears the internal part of generator 53 that in its turn is a component of ice-protection system. The generator is joined by studs 51 and nuts. The braces 54 fix wires going from the generator to the blades. Each brace is joined to the cylinder by two screws that in their turn are wire-locked.

The piston assembly consists of piston 61, cross-bar 63 and guide tube 67. The piston is made of duralumin, the cross-bar and the tube are made of steel. The groove at the external surface of the piston serves for the rubber gasket 55 mounting. The inner surface of the piston also has two grooves: for bronze sleeve 65 and for the seal rubber gasket 66.

The piston is screwed to the cross-bar. Their mutual shift is constrained by fixing pin 62. The way cross-bar is interconnected with connecting rod 71 and pipe 67 are similar to that of the front propeller. The upper surface of cross-bar has the milled flat surface. The casing 58 of the stop dowel is joined to it by two screws. The stop dowel 60 can travel in the slots of the casing. The intermediate stop is adjusted by screw 59 that moves the stop dowel in the slots of the casing. Having been adjusted, the screw is locked by wire.

The casing. The face area has the flange with twenty-four studs 57 for the cylinder attachment. The cylinder wall contains three oil channels and a socket to secure the centrifugal pitch stop 70, which is the intermediate hydraulic stop at the same time. The stop consists of pilot valve, casing, nut and spring. The casing is joined to the shaft of gearbox by face splines and sixteen power studs. The collector 78 is attached to the tail part of casing. It has two contact rings that supply the current to the field coil of generator SG-24.

The oil collector 73 with steel sleeves collects the oil that gets to the rear propeller from the engine shaft. The oil collector is centered regarding the casing by the pin. They are joined by eight screws. The rubber cuff 74 seals the face surface of the shaft and the oil collector.

Construction of the cartridge mounting in the rear propeller hub is similar to the cartridge mounting in the front one.

5.3. Propeller blades

The propeller blades are made of duralumin. The blade consists of an airfoil and a root (threaded component). The root has the drilled hole for fitting the balancing weight 28. The balancing weight cannot slip out due to fixing spacer 27.

The leading edge of the blade is heated by the elements made of electroconductive rubber.

As the rear propeller rotates anticlockwise (looking from the engine), the moment of transversal components of centrifugal forces also trends to turn the blade in cartridge anticlockwise.

Therefore, the root of rear propeller blade has the left-hand thread, preventing its unscrewing under the mentioned forces action. The front propeller blade root is right-hand threaded.

5.4. Ice protection system

The ice protection system protects blades and cowl from ice formation in flight.

It contains the following elements: AC generator SG-24, heating elements on blade and cowl faces, automatic timer AVP-18A, contactor K-100D, switch B-45, current collector and conductive accessories.

The generator SG-24 supplies electric current to the heating elements. It consists of two parts (Fig. 5.2): contra-rotating outer rotor 2 and inner rotor 4.

The inner rotor is mounted on the carter of cylinder of the rear propeller. It is studded and pinned.

The outer rotor is mounted to the disc of the front propeller. It is also studded and pinned.

The field coils of generator are powered by the airborne network through the contactor K-100D (the voltage is 27 V, the amperage is 45 A).

Specifications of electric generator:

Power	24 kW
Voltage	208 V
Power of each rotor	12 kW
Field current	27 V
Field amperage	45 A
Operating mode	intermittent cycle

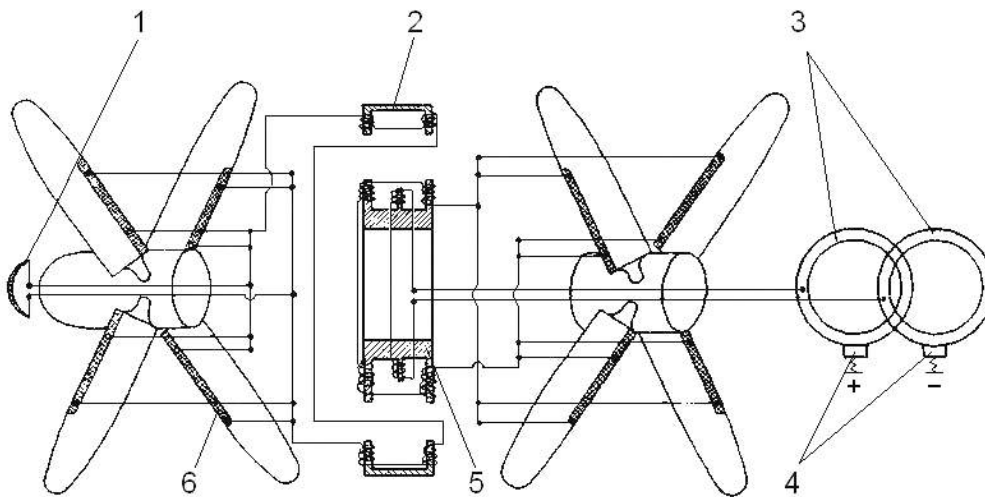

Fig. 5.2. Ice protection system of AV-60 propeller:

- 1 – heating element of cowl; 2 – outer rotor of generator; 3 – collector;
 4 – current receiver; 5 – inner rotor of generator; 6 – heating element of blade

The inner rotor of electric generator powers the heating elements of rear propeller blades. The outer rotor of generator powers the heating elements of front propeller blades and cowl.

The heating element 6 of the blade is a current-conductive rubber cover that is glued into a special slot. The latest is milled in the leading edge of blade. The heating element has two conductive bus bars. Ends of the bus bars jut out. They are connected to the terminals of generator SG-24.

The heating elements are taped from the blade surface by the isolating layer. They take 208 V, 45...650 Hz AC. The amperage of the front propeller is 10 A, amperage of the rear propeller is 15 A.

The heating element 1 of propeller cowl 4 is made of aluminum foil. It is heated by power 3.5 kW provided by the outer rotor.

Automatic timer AVP-18A alternately switches the field current of the generator SG-24 between on and off. It has six operating modes that are set according to the operating conditions.

The airborne electrical network powers the automatic time device via the current collector 4 (voltage 27 V). The collector consists of a casing with a plug-and-socket connection, and brushes inside the casing. The current collector 78 (see Fig. 5.1) is studded to the bracket of protective cover 75.

The collector 3 (see Fig. 5.2) consists of two contact rings 77 (see Fig. 5.1) connected to the generator's field coil by electric conductors. The collector is screwed to the tail of rear propeller casing. The wires from the generator SG-24 to the heating element have a loop, which allows for the free blade cartridge turning within the range from φ_0 to φ_f .

The outer part 2 of generator SG-24 powers the cowl. The ends of wires from side of the cowl are built in a connector. The latest is mounted inside the pipe that is used for cowl centering.

6. AIRCRAFT PROPELLER AV-68I

6.1. General

AV-68I 3 series is a four-blade aircraft propeller for AI-20 turboprop. The propeller converts rotary motion from an engine into thrust for flight or into negative thrust – for speeding down the aircraft during landing run.

The speed governor R68D and the auxiliary control equipment maintain constant rotational speed due to the automatic alternation of the propeller blade angle. Besides, the governor and auxiliary control equipment:

- automatically move the blades to the intermediate stop;
- forcedly move the blades off the intermediate stop;
- automatically or forcedly feather the blades;
- forcedly move the blades from the feathered position;
- move the blades to the minimum rotation drag angle position.

The hydraulic pitch control is back-action. The pitch is increased by oil pressure that is fed by the speed governor to the cavity A (Fig. 6.1). The pitch is decreased as by the moments of transversal components of centrifugal forces, so by the oil that gets into the cavity B from the oil line of the engine. At the same time, piston forces oil out from the cavity A to inside of the engine casing.

When, due to some reasons, the pressure in the cavities drops, the propeller is fixed simultaneously by HPS and MPS. The MPS is able to fix the blade at any blade angle within the range from 45° to 0° , and the HPS – within the range from 83° to 0° .

If the rotational speed exceeds 1115^{+15} rpm, then the CPS will automatically terminate the pitch alternation using the HPS or MPS.

The IPS fixes the blade at some position between the maximum and minimum pitch, thus preventing high negative thrust. This is very urgent when the aircraft descends until the touchdown and the engine power setting decreases. When the airplane makes the go-around, then the engine sharply increases the power setting. The blades being fixed at intermediate angle let the fast propeller loading and, hence, takeoff thrust gaining.

Characteristics of propeller AV-68I

Type of the propeller – tractor propeller of variable pitch with feathering and intermediate stop

Number of blades 4

Diameter 4.5 m

The maximum blade width 0.405 m

Hand of rotation (flight looking forward): left

Rotational speed (takeoff)

– propeller 1075 rpm

– engine 12300 rpm

Blades turning mechanism	hydro-centrifugal
Blade angle at control section $R = 1.6$ m:	
– angle of minimum rotational drag (starting angle) φ_0	0°
– intermediate stop angle φ_{IS}	12°
– feathering angle φ_f	$83^\circ 30'$
Mass	$385^{+2\%}$ kg
Time interval of in-flight feathering (max time)	10 s

6.2. Construction

The AV-68I propeller consists of the following assemblies and parts:

- propeller hub;
- four blades;
- ice-protection system.

6.2.1. Propeller hub

The propeller hub (Fig. 6.1) consists of casing 4, cartridges 45, clamps 37 with bolts 36, nuts 35 for fixing cartridges, fixing spacers 43, balls 33 and 34 with cage.

The casing is a main load-bearing element of the hub. It bears the blades and other components of the propeller. It serves fitting and fixing the propeller to the face of a gearbox shaft.

The casing takes centrifugal and aerodynamic forces, bending moments of these forces and gyroscopic moment that originates during the aircraft maneuvers. The casing is an all-in-one-part made of high-strength steel alloy.

The seats (cantilever arms) with the cartridges 45 inside carry the blades. Each cartridge rests in a tree-row blade retention bearing 33.

Each row contains 36 balls with the same group of selection and a duralumin cage.

The rear wall of casing has a hole, the face of which is splined. An oil line 3 passes inside of the hole.

Cartridges 45 are made of steel alloy. The inner face of each cartridge is threaded for the propeller blades mounting. Pin 38 prevents the blade turn in the cartridge. The cartridge is secured in the seat by nut 35. The inner surface of the nut holds splines that are in charge of fixation spacer mounting. The undersurface of the nut and the face of the seat are of high finish, because they serve as racers for balls 34.

The blade is secured in the cartridge by clamp 37 that is inserted in the clamp's fillet and tightened by bolt 36. Three cuts at the top of the cartridge provide reliable contact between the blade root and the cartridge. They also prevent angular shift of the blade and help the clamp in blade tightening mission.

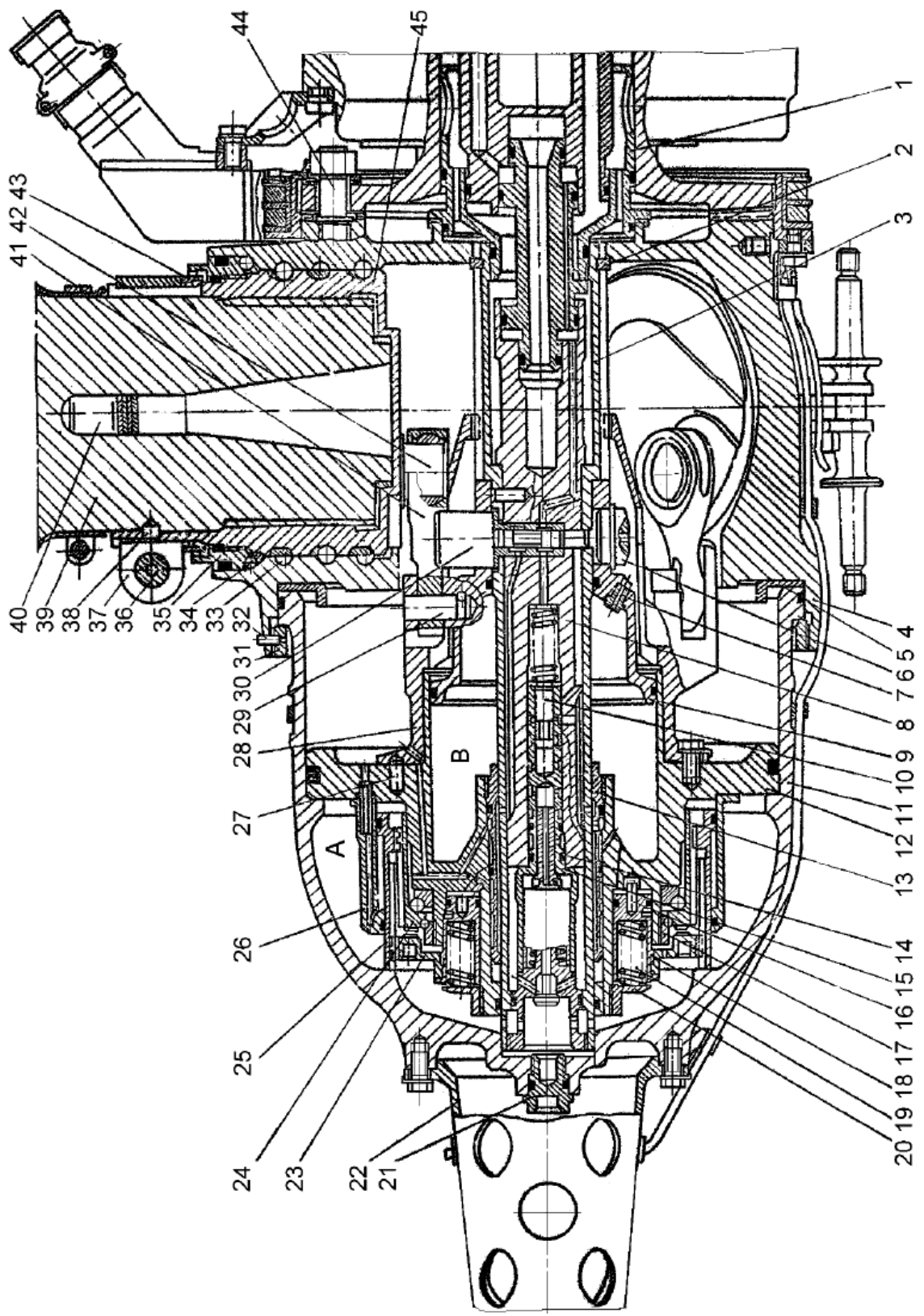

Fig. 6.1. Hub of aircraft propeller AV-681

The bottom end has an eccentrically arranged pin 42 that is made all-in-one with the cartridge. Connecting rod 41 connects cartridge with cross-bar 28. The rod is also joined to the pin.

Connecting rod 41 transforms the rectilinear motion of the cross-bar into turning of the cartridge. The pin is hinge-joined to the connecting rod. It allows the connecting rod operation at some warp. The connecting rods are joined to eyes by hinged pins 29.

The piston assembly consists of cylinder 11, connecting rods 41 and hub 22 that centers the propeller cowl.

A duralumin cylinder 11 is joined to the casing by nut 31. The nut is locked by screw locking device 32.

When the cylinder is mounted, bleed valve 21 bleeds the air. The valve is mounted on the front face of the cylinder.

The piston assembly consists of piston 12, small-diameter cylinder 26, splined hub 25, swiveling hub 24, ball bearings, spring-sleeve 18, cross-bar 28, oil line 3, HPS with pilot valve 14 and CPS 30.

The piston assembly is sealed with annular gaskets made of oil-proof rubber.

The piston 12 is made of duralumin. When the propeller blades approach the φ_0 stop, the piston comes to a boss inside the cylinder. The feathering angle is adjusted by ring 5, the width of which sets the feathering angle.

The piston has fillets for inserting the seal rings and spring-sleeve 18. Six studs 16 prevent the spring-sleeve from being turned in regard to the piston.

The following parts are screwed to the piston: adjustment sleeve 13, nut of the piston 20, and nut of the bearing, small-diameter cylinder 26 and cross-bar 28. Pin 27 centers the cross-bar in regard to the piston.

The inner surface of the left end of the hub 25 has splines milled longitudinally. Mechanical stop 23 slides in these splines. The right side of this surface is threaded. The thread has a square profile that suits the most for screwing and unscrewing the steel swiveling hub 24.

The left face of the swiveling hub 24 has radial face splines that join the turning hub with splines of the clutch of mechanical stop 23, when the mechanical stop is brought to action.

The clutch of mechanical stop 23 is threaded to the spring-sleeve 18. The inner face of the clutch has longitudinal splines that serve the clutch sliding in splines of the splined hub 25.

The hydraulic pitch stop (HPS) is a mitre valve that is mounted in front part of the oil line 3. The HPS blocks the blade position when the pressure in the oil line drops due to the failure of a speed governor or a propeller control system.

When the propeller hub operates at a normal mode, the valve is kept open by the oil that is delivered to the piston. When the oil pressure drops, the spring forces the valve to move right until it blocks the oil outflow from the

cavity A. The residual oil in this cavity plays the role of the hydraulic pitch stop, thus, preventing the propeller pitch reduction and its overspeed.

The mechanical pitch stop (MPS) makes the propeller pitch fixation more reliable. It snaps into action simultaneously with hydraulic pitch stop and fixes the blades only when the pitch decreases. The mechanical pitch stop does not block the blade repositioning when it attempts to increase the blade angle.

When the driving mechanism operates at normal mode, the piston can swimmingly move in the cylinder along the axis thanks to a free rotation of the swiveling hub 24. As soon as the swiveling hub with the hub of hydraulic pitch stop 23 travel left, being forced by the oil pushing the right face of the spring sleeve 18, the face splines of the swiveling hub 24 and the hub of hydraulic pitch stop become disengaged.

When the propeller pitch is hydraulically stopped, both cavities, the cavity under the HPS valve and the cavity on a left from the spring-sleeve, are interconnected with the drain line. The mitre valve of HPS closes and the propeller finds itself on the hydraulic stop. Simultaneously, the springs 18 force the spring-sleeve and the hub of hydraulic stop rightwards. The spring-sleeve becomes interlocked with the turning hub. As the splined hub 25 reached the face of propeller's cylinder and rests on it, the swiveling hub has no more chance for turning and the piston becomes constrained from any motion to the left (i.e. to lower pitch angles region).

The cross-bar 28 has eyes on outer surface to fit the connecting rods. On its right side, the cross-bar has inner splines to slide on the outer splines of the oil line 3. The splines preserve the cross-bar from the turn in the casing and unambiguously determine the position of the connecting rods in regard to the pins of blade cartridge.

Piston 12 slides on diaphragm 9. The wall of the diaphragm has an orifice 7 that serves the oil circulation, which in its turn heats the propeller hub.

The diaphragm also bears centrifugal stop 30 and counterweight 6.

The centrifugal pitch stop (CPS) consists of spring-loaded valve with counterweight. When the propeller rotational speed exceeds the limit (1115⁺¹⁵ rpm), the centrifugal force of the pilot valve overcomes the tightening of the spring. The pilot valve moves and interconnects the cavity under the piston of HPS and the cavity on the right from the spring-sleeve of MPS to the drain line. This is the way hydraulic and mechanical fixation happen, thus preventing the further rotational speed growth.

The steel adjusting sleeve 13 has holes, fillets and slots that serve the propeller to get to intermediate pitch stop (φ_{IS}). At this position the propeller blades loose any chance to move to the minimum pitch when the engine power decreases (for example before landing or when the engine fails in flight).

The intermediate pitch stop. When the pitch grows, the IPS does not fix the blades at φ_{IS} . And vice versa when the pitch decreases, the blades reach the intermediate pitch stop angle. The holes in the adjustment hub and the oil

line became interconnected, connecting cavities of HPS and MPS to the drain line. The simultaneous hydraulic and mechanical fixation of the propeller pitch is implemented at $\varphi = \varphi_{15}$; that is very important to escape of the high negative thrust.

The oil line consists of the steel pipe 3, duralumin casing pressed in the pipe, steel sleeve 15, elements of HPS, pilot valve 10 and spring 8. The oil line is joined to the propeller casing by the nut 1 and is axially fixed by C-ring 2.

Elements engaged in propeller fitting on an output shaft of the gearbox. The rear face of hub casing has face splines and sixteen power studs for studding the propeller to the flange of the gearbox shaft. The torque is transmitted from the shaft to the propeller via the triangular face splines Thrust is transmitted from propeller to the shaft by the studs.

The spinner is corbeled on four cantilevers bolted to the cuffs of the casing. Sleeve 22 centers the cowl.

6.3. Blades

The blades are made of duralumin. Airfoil (body) generates the thrust, and root 39 secures the blade in the cartridge.

The blade of 58 kg mass generates the 636 kN of centrifugal force. The propeller rotates anticlockwise (flight looking forward), so the moment of transversal components of centrifugal forces trends to turn the blade in the cartridge anticlockwise.

Therefore, the left-side thread is used to make the mentioned forces screw the blade into the cartridge.

The blade root has the hole for mounting the balancing weight 40 and spacers. The positions of the weights and the spacers are chosen at balancing and fixed by the fixation spacer.

Having been assembled, the propeller blades are not interchangeable anymore because of different mass and sizes.

6.4. Ice protection system

During flight at ice-accretion conditions, the ice may cover the leading edges of blades, deteriorating the aerodynamic performances and causing the vibration. To prevent the icing, the heating elements are pasted on the cowl foreside and the leading edges of blades. To minimize the impact of the heating elements on the blade aerodynamic performances, they are inserted into special cutouts in the leading edges.

Two wires jut out the heating element, which ends are connected to the terminals of contact rings.

The heating elements are put into action at regular intervals; they melt the ice covering the leading edges of blades and propeller cowl. The melted ice turns into water film separating the ice from the blade face. The adherence

between the ice and the surface diminishes and the centrifugal forces put the ice off the blade face.

The heating element looks like a stainless-steel strip of 0.1...1.12 mm thick. This strip is between some layers of glass cloth. The heating element is covered with the thermal-resistant rubber that is able to work reliably at temperature span -30...+100 °C. The heating pad is covered by 0.3 mm thick strip made of stainless steel to protect the pad from the most probable damages. The strip ends are cut for lower rigidity. This is the way they are protected from cracking.

The AC electric generator SGO-8 powers the ice protection system. The system is switched on and off at regular intervals specified by the PMK-24 (24 s – on, 24 s – off). The consumed power is 6.5 kW.

7. AIRCRAFT PROPELLER AV-140

7.1. General

AV-140 is a six-blade aircraft propeller for TV3-117VMA-SB2 turboprop. The propeller converts rotary motion from an engine into thrust for flight or into negative thrust – for speeding down the aircraft during landing run.

The speed governor RSV-34M and the electronic governor RED-2000 maintain constant rotational speed due to automatic alternation of the propeller blade angle at all power settings except the idle and thrust reversing.

At these power settings, the propeller operates as the fixed-pitch propeller with rotational speed set by the automatic fuel control system.

The propeller has two mechanical stops (feathering stop φ_f and reversing stop φ_{rev}) and two hydraulic stops (intermediate pitch stop φ_{IS} and minimal rotation drag stop φ_0). The φ_0 stop works at idle.

The propeller is equipped with the device, which automatically fixes the blades at angle φ_{IS} (when the blade angle becomes lesser and no command to unstop φ_{IS}). The other device fixes the blades at any angle in the range $\varphi_{IS}... \varphi_{max}$ in case the oil pressure in the channel of the pitch stop drops spontaneously to a preset value (the value of the HPS actuation).

φ_{IS} unstopping, reversing, reversing put-out and unfeathering are done forcedly; feathering is done automatically and forcedly.

At propeller overspeed (104 %), the RED-2000 forms the command for blades fixation.

The propeller carries an electrical ice protection system (IPS) that is powered with three-phase electric current. The current is supplied to the heating elements of blades and cowl through the current collector that has three working rings and one bonding strip.

The wires that supply current to the heating elements are in the propeller hub.

Characteristics of AV-140 propeller

Type of propeller – tractor VPP with feathering and intermediate stops	
Number of blades	6
Diameter	3.72 m
Hand of rotation (looking along the flight):	left-hand
Rotational speed (takeoff)	1200 rpm
Blade turning mechanism	hydro-centrifugal
Blade angle at control section $R = 1.45$ m:	
– angle of minimum rotational drag (starting angle) φ_0	0°54'
– intermediate pitch stop angle φ_{IS}	9°24'
– feathering angle φ_f	82°03'
Mass	210 kg
Time interval of in-flight feathering (max time)	5 s

7.2. Construction

The AV-140 propeller consists of the following assemblies and parts:

- propeller hub;
- six blades;
- ice protection system.

7.2.1. Unit of propeller hub

The propeller hub consists of casing 24, cartridges 14, clamps 12 and parts of cylinder assembly (Fig. 7.1).

The casing 24 is a main load-bearing element. It bears assemblies and parts of the propeller hub. It serves fitting and fixing (twelve studs 20 and nuts 19) the propeller to the face of a gearbox shaft. The studs are pressed in casing 24.

The pin 15 positions of the propeller regarding to the shaft of the gearbox. When the propeller is mounted, the pin enters the counter hole in the gearbox shaft.

The blades 10 are mounted in six cuffs of the casing 24. Each blade is screwed into the cartridge 14 that rests on the cuff with the two-row blade retention bearing.

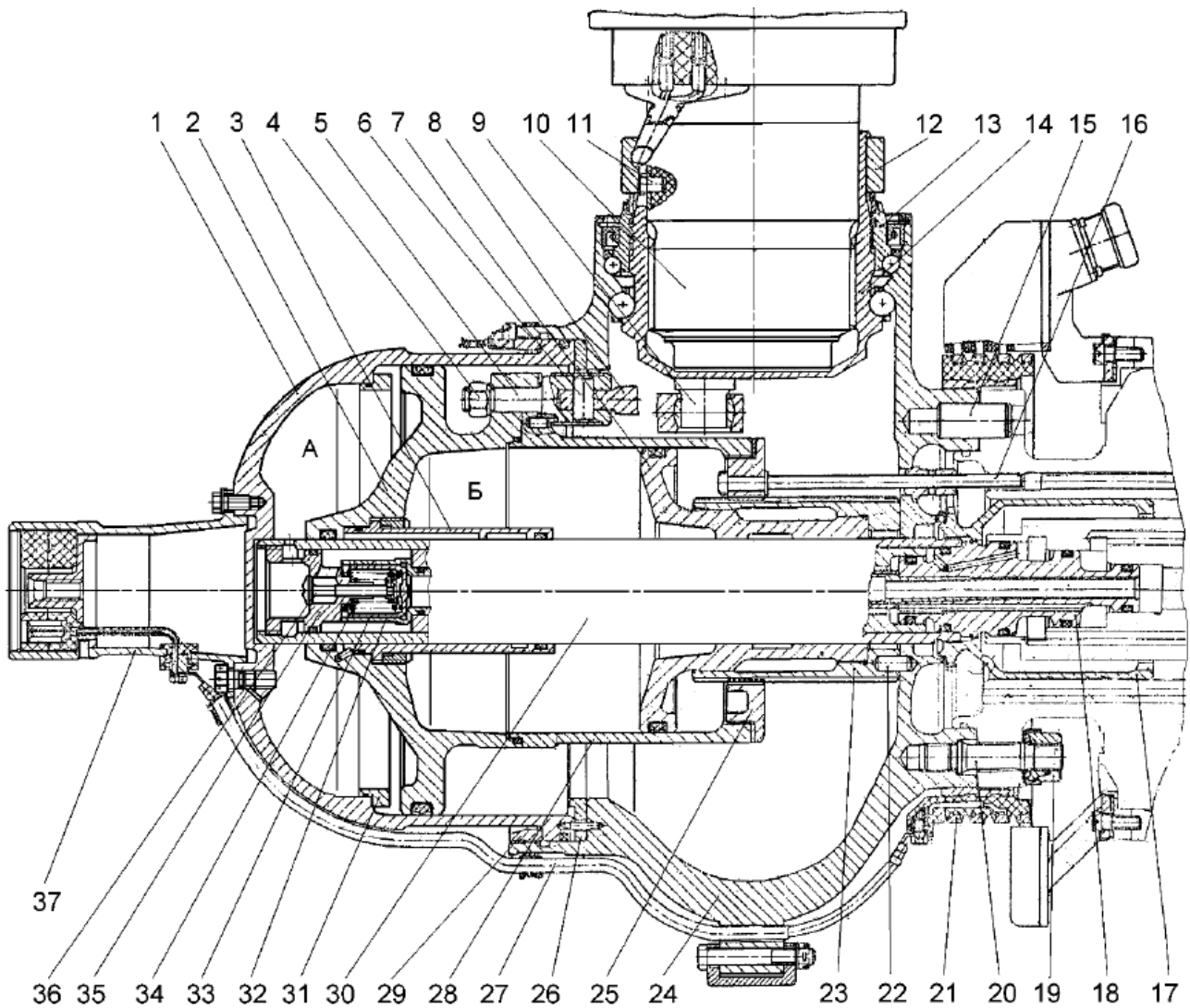

Fig. 7.1. Hub of aircraft propeller AV-140

The cuff serves as the outer racer of the blade retention bearing. It has two grooves (bearing racers). The inner racers are the cartridge 14 with a single groove and the nut of cartridge 13 with the other single groove. The nut of cartridge 13 provides negative allowance in bearing.

The blade 10 is threaded into the cartridge 14. Position of the blade is determined by pin 11.

The nut-bolt joint tightens the clamp 12. The cartridge has two cuts that make it elastic to snap the blade root in the cartridge, thus providing a reliable blade fixation.

Face of the cartridge has the eccentrically arranged pin 9 that is a part of the crank-and-rod mechanism. It joins the cartridge with piston 2 and transforms a rectilinear motion of the piston into the blade turning. This mechanism consists of pin 9, connecting rod 8, pin of the connecting rod and rod 5.

Three cantilevers are circumferentially equidistant at 120° . They serve the propeller cowl fixation.

The *cylinder-piston assembly* of propeller consists of cylinder 1, piston subassembly, cross-bar 28, diaphragm 7 and oil pipeline subassembly 30.

The cylinder 1 is joined to casing 24 by the nut of cylinder 29. It displaces the subassemblies and the parts of the cylinder-piston assembly and forms the working cavities of the propeller.

The hub 37 of propeller cowl is bolted to the cylinder 1. The electric current is supplied to the heating element through the plug connector inside the hub 37.

The piston assembly 2, diaphragm 7, cross bar 28, casing 24, cylinder 1 and oil pipeline 30 limit the working cavities of propeller:

- coarse pitch cavity (A);
- fine pitch cavity (B);
- drain cavity.

The piston subassembly consists of piston 2 and adjusting hub 3. The piston 2 alternates the blade angular position via the crank-and-rod mechanism. The extreme positions of the piston are reverse stop 31 and feather stop 26.

Hub 3 fixes pitch controlling mechanism at blade angles φ_{1S} and φ_0 .

Cross-bar 28 is interconnected with the piston 2 via the rod 5 and the nut 4.

The splined collar 25 is screwed in the cross-bar. It is also splined with hub 23, preventing the cross-bar 28 and the piston 2 from the angular shift.

Splines of hub 23 guide piston 2 and cross-bar 28. Splined hub 23 is constrained from turning by pins 22.

The oil pipeline 30 feeds the propeller cavities with the oil from the oil receiver. It consists of pipeline, casing of pipeline and valves that are placed inside both: HPS valve, φ_0 valve and reversing put-out and IPS valve.

The HPS valve blocks the oil outflow from the cavity B when the pressure becomes less than that in the HPS channel. This happens in case when the safety catches are put into action or when propeller blade is at an intermediate pitch stop.

The HPS consists of piston 33, casing of stop 35, springs 34, valve 36, hub 32.

The valve of φ_0 and reversing put-out supplies the oil at high pressure to the cavity B when propeller blades are driven from reversing position to angle φ_0 .

The valve of intermediate unstopping switches the HPS valve off when the unstop command comes.

The push bar 16 indicates the blade angle position to the feedback sensor that is used in the engine control system.

Oil pipeline 30 and oil collector 18 are fixed from axial displacement by the nut of oil pipeline 17.

7.3. Blades

The propeller blades are made of polymer-composite material. The airfoil generates the thrust, the root 10 secures the blade in the cartridge of propeller hub.

As the propeller rotates anticlockwise (flight looking forward), the moment of transversal components of centrifugal forces also trends to turn the blade in the cartridge to the same side. Therefore, the root of propeller blade has the left-hand thread to screw the the blade into the cartridge.

The leading edge of blade has heating elements that protect the blade from ice formation.

7.4. Ice protection system

The ice protection system includes the following elements:

- heating elements;
- wiring;
- plug connector;
- current collector.

The heating element is glued on the leading edge. It is made of constantan wire and covered from both sides with polyurethane. Its resistance is $29.5 \pm 0.7 \Omega$. The current collector TSV11U031 transmits electric current to the heating elements.

The heating elements are wired to the terminals of the current collector 21. The wires have predetermined length and create loops in an interface zone. The loops let the blades turn free in the entire operating range.

The heating element of cowl is wired (electric wires 27 and plug connector) to the current collector 21.

The current collector 21 consists of contact rings that are mounted on propeller casing, and boxes that keep electric brushes and metallization brushes.

The ice protection system (IPS) is actuated automatically by an icing indicator or manually – by a button. The automatic control system puts the IPS to action from time to time. The time span depends on ambient temperature.

The operating time may vary within the range 9...62 sec, depending on ambient temperature alternation (0...–25 °C).

CHECK QUESTIONS

1. Name requirements made to aircraft propellers.
2. What are the purposes to drive the propeller through the gearbox?
3. Which elements do aircraft propeller consist of?
4. Draw the velocity polygon of a propeller blade and mark the main velocities, attack angle and inflow angle.
5. How are propeller thrust and consumed power generated?
6. How is propeller efficiency determined?
7. Give a description of main operating modes of aircraft propeller, set signs of thrust and power and relation between the blade angle and the attack angle.
8. Which forces and moments do act on propeller blade?
9. To which side the centrifugal forces do propeller blade turn?
10. Why does the propeller pitch vary?
11. Which propeller (direct or back action) is equipped with counterweights? What is their function?
12. What advantages do the coaxial propellers have?
13. What is the difference between reversible and conventional propellers?
14. When can the negative thrust appear?
15. What is feathering? What are conditions operating for feathering? Why does the feathering system need a pump?
16. Name methods of propeller blades driving to the feathering position. What are their advantages and disadvantages?
17. When are the propeller pitch stops applied?
18. Describe the operation of the hydraulic pitch stop.
19. Describe the operation of the mechanical pitch stop.
20. Describe the operation of the centrifugal pitch stop.
21. When the intermediate stop is used?
22. Describe the operation of the intermediate pitch stop.

GLOSSARY ON AIR PROPELLERS

English	Russian	Ukrainian
Aeromechanical propeller	Аэромеханический винт	Аеромеханічний гвинт
Add-on device	Дополнительное устройство	Додатковий пристрій
Adherence	Сцепление (льда с поверхностью)	Зчеплення (льоду з поверхнею)
Adjusting washer	Регулировочная шайба	Регулювальна шайба
Advance	Эффективный шаг винта	Ефективний крок гвинта
Aircraft propeller; airscrew	Воздушный винт; винт	Повітряний гвинт; гвинт
Automatic time device	Автомат времени	Автомат часу
Back action propeller	Винт обратного действия	Гвинт зворотної дії
Back-up plate	Опорная шайба	Опорна шайба
Bearing race	Беговая дорожка подшипника	Бігова доріжка підшипника
Bearing cage	Сепаратор подшипника	Сепаратор підшипника
Bearing sleeve	Стакан подшипника	Стакан підшипника
Blade	Лопасть винта	Лопать гвинта
Blade root	Комель лопасти	Гузир лопаті
Boss	Бобышка, выступ	Бобишка, виступ
Brace	Скоба	Скоба
Brass gauze	Латунная сетка	Латунна сітка
Bracket	Кронштейн	Кронштейн
Breaking mode	Режим торможения	Режим гальмування
Brush of current collector	Щетка токосъемника	Щітка струмознімача
Bus	Электрическая шина	Електрична шина
Bus bar	Токопроводящая шина	Струмопровідна шина
Casing of propeller (hub spider)	Корпус втулки винта	Корпус втулки гвинта

English	Russian	Ukrainian
Cartridge	Стакан (крепления лопасти)	Стакан (кріплення лопаті)
Centrifugal pitch stop	Центробежный фиксатор шага	Відцентровий фіксатор кроку
Clamp	Хомут	Хомут
Cloth laminate	Текстолит	Текстоліт
Coarse pitch	Большой шаг	Великий крок
Coaxial propeller	Соосный винт	Співвісний гвинт
Connecting rod	Шатун	Шатун
Counterpart (of junction)	Ответная деталь (соединения)	Відповідна деталь (сполучення)
Counterweight	Противовес	Противага
Cover	Заглушка	Заглушка
Spinner (of air propeller)	Обтекатель (воздушного винта)	Обтічник (повітряного гвинта)
Crank-and-gear mechanism	Кривошипно-шатунный механизм	Кривошипно-шатунний механізм
Cross bar	Траверса	Траверса
Cuff	Манжета, рукав	Манжета, рукав
Current collector	Токоъемник	Струмознімач
Current receiver	Токоприемник	Стумоприймач
Cut	Прорезь	Проріз
Cutout	Выемка	Виїмка
Defeathering	Расфлюгирование	Розфлюгування
Dereversing	Вывод из реверсивного положения	Виведення з реверсивного положення
Direct action propeller	Винт прямого действия	Гвинт прямої дії
Double action propeller	Винт двойного действия	Гвинт подвійної дії
Dowel	Сухарь	Сухар
Drain line	Дренажная магистраль	Дренажна магістраль
Drive fit	Тугая посадка	Туга посадка

English	Russian	Ukrainian
Driving force	Перестановочное усилие	Переставне зусилля
Electric propeller	Электрический винт	Електричний гвинт
Electromechanical propeller	Электромеханический винт	Електромеханічний гвинт
Engine casing	Картер двигателя	Картер двигуна
Exchangeable	Взаимозаменяемый	Взаємозамінний
Feathering	Флюгирование	Флюгування
Field coil	Обмотка возбуждения	Обмотка збудження
Fine pitch	Малый шаг	Малий крок
Fine pitch stop	Фиксатор малого шага	Фіксатор малого кроку
Fixed pitch propeller	Винт фиксированного шага	Гвинт фіксованого кроку
Forcing stud	Силовая шпилька	Силова шпилька
Frictioned fabric	Прорезиненная ткань	Прогумована тканина
Hub of propeller	Втулка винта	Втулка гвинта
Hydraulic pitch stop	Гидравлический фиксатор шага	Гідравлічний фіксатор кроку
Hydraulic propeller	Гидравлический винт	Гідравлічний гвинт
Geometric pitch	Геометрический шаг	Геометричний крок
Get a stop	Становиться на упор	Становитися на упор
Glass cloth	Стеклоткань	Склотканина
Go-around flight maneuver	Уход на второй круг	Схід на друге коло
Groove	Выточка	Виточування, виточення
Ice protection system	Противообледенительная система	Протиобліднювальна система
Inductive velocity	Индуктивная скорость	Індуктивна швидкість
Intermediate stop, intermediate rest	Промежуточный упор	Проміжний упор
Jet	Жиклер	Жиклер

English	Russian	Ukrainian
Jets affluent angle	Угол натекания струй	Кут натікання струменів
Landing approach	Заход на посадку	Захід на посадку
Linear motion	Поступательное движение	Поступальний рух
Mechanical pitch stop	Механический фиксатор шага	Механічний фіксатор кроку
Mechanical propeller	Механический винт	Механічний гвинт
Mitre valve	Грибковый клапан	Грибковий клапан
Multiple-row bearing	Многорядный подшипник	Багаторядний підшипник
Offset distance	Дезаксаж (дезаксиал)	Дезаксаж (дезаксіал)
Oil header	Маслоприемник	Маслоприймач
Oil seal ring	Маслоуплотнительное кольцо	Маслоущільнювальне кільце
Oil thrower ring	Маслоотражательное кольцо	Масловідбивне кільце
Paste	Наклеивать	Наклеювати
Pilot valve	Золотник	Золотник
Plug and socket connection, Plug connector	Штепсельный разъем	Штепсельний рознім
Pitch	Шаг	Крок
Polygon of velocities	Многоугольник скоростей	Багатокутник швидкостей
Propelling mode	Пропеллерный режим	Пропелерний режим
Propfan	Винтовентилятор	Гвинтовентилятор
Pump-out	Откачивать	Відкачувати
Pusher propeller	Толкающий винт	Штовхальний гвинт
Push bar	Толкатель	Товкач
Rectangular shape blade	Прямоугольная лопасть	Прямокутна лопать
Reversible propeller	Реверсивный винт	Реверсивний гвинт

English	Russian	Ukrainian
Rubber gasket	Резиновое кольцо	Гумове кільце
Running in place mode	Режим работы на месте	Режим роботи на місці
Scimitar shape blade	Саблевидная лопасть	Шаблеподібна лопать
Scoop pump	Черпаковый насос	Черпакова помпа
Seal failure	Разгерметизация	Розгерметизація
Single direction propeller	Винт одностороннего действия	Гвинт односторонньої дії
Skew	Перекося	Перекіс
Sleeve	Гильза	Гільза
Slip function	Поступь винта	Поступ гвинта
Splint	Шплинт	Шплінт
Spring-loaded	Подпружиненный	Підпружинений
Spring tension	Затяжка пружины	Затяжка пружини
Stop	Упор	Упор
Swage	Обжимать	Обтискувати
Subsonic propeller	Дозвуковой винт	Дозвуковий гвинт
Supersonic propeller	Сверхзвуковой винт	Надзвуковий гвинт
Swiveling hub	Поворотная втулка	Поворотна втулка
Take off a stop	Снимать с упора	Знімати з упору
Terminal	Клемма	Клема
Through hole	Сквозное отверстие	Наскрізний отвір
Tightness	Натяг	Натяг
Tractor propeller	Тянущий винт	Тягнучий гвинт
Transonic propeller	Трансзвуковой винт	Трансзвуковий гвинт
Variable pitch propeller	Винт изменяемого шага	Гвинт змінного кроку
Windmilling mode	Режим авторотации	Режим авторотації
Wind turbine mode	Режим ветряка	Режим вітряка
Zero thrust mode	Режим нулевой тяги	Режим нульової тяги

BIBLIOGRAPHY

Авиационный турбовинтовой двигатель НК-12. – М. : Оборонгиз, 1957. – 254 с.

Александров, В. Л. Воздушные винты / В. Л. Александров. – М. : Оборонгиз, 1951. – 475 с.

Воздушные винты АВ-68И серии 02 и 03 и регулятор постоянных оборотов Р68Д. – М. : Оборонгиз, 1960. – 194 с.

Воздушный винт АВ-140: руководство по техн. эксплуатации АВ-140.000.000. РЭ-ЛУ, 1995. – 127 с.

Кириченко, В. И. Редукторы ТВД и вертолетных двигателей / В. И. Кириченко. – Харьков : ХАИ, 1970. – 82 с.

Штода, А. В. Конструкция авиационных газотурбинных двигателей / А. В. Штода, В. А. Секистов, В. В. Кулешов. – Киев : КВВАИУ, 1982. – 435 с.

Airframe and Powerplant Mechanics. Powerplant Handbook with Index / Dept. of Transportation. Federal Aviation Administration. Flight Standards National Field Office, 1996. – 519 p.

Kroes, M. J. Aircraft Powerplants, 7-th edition / M. J. Kroes, T. W. Wild. – GLENCOE Aviation Technology Series, 1995. – 704 p.

Навчальне видання

**Кравченко Ігор Федорович
Єпіфанов Сергій Валерійович
Гаркуша Олександр Іванович**

ПОВІТРЯНІ ГВИНТИ

(Англійською мовою)

Редактор К. А. Дубінін
Технічний редактор Т. В. Савченко

Зв. план, 2020

Підписано до друку 16.03.2020

Формат 60×84 1/16. Папір офс. № 2. Офс. друк

Ум. друк. арк. 3,6. Обл.-вид. арк. 4. Наклад 50 пр.

Замовлення 81. Ціна вільна

Видавець і виготовлювач
Національний аерокосмічний університет ім. М. Є. Жуковського
«Харківський авіаційний інститут»
61070, Харків-70, вул. Чкалова, 17
<http://www.khai.edu>
Видавничий центр «ХАІ»
61070, Харків-70, вул. Чкалова, 17
izdat@khai.edu

Свідоцтво про внесення суб'єкта видавничої справи
до Державного реєстру видавців, виготовлювачів і розповсюджувачів
видавничої продукції сер. ДК № 391 від 30.03.2001